



USER'S MANUAL
NX FREQUENCY CONVERTERS

BASIC I/O BOARDS
EXPANDER I/O BOARDS
ADAPTER BOARDS

INDEX

Document code: ud00741M

Date edited: 25.02.2011

1.	General information.....	4
1.1	Board slots on the control board of Vacon NXS and NXP	4
1.2	Board Slots on the control board of Vacon NXL	5
1.3	Option board types	5
1.4	Technical data	7
1.4.1	Isolation	7
1.4.2	Analogue inputs (mA/V)	7
1.4.3	Analogue outputs (mA/V)	8
1.4.4	Control voltage (+24V/EXT +24V)	8
1.4.5	Digital input signal conversion	8
1.5	Hardware protections	10
1.5.1	Terminal block coding.....	10
1.5.2	Board slot guides and allowed slots	10
1.6	Type identification number.....	10
1.7	Defining functions to inputs and outputs.....	10
1.8	Defining a terminal for a certain function with NCDrive programming tool.....	12
1.9	Option board related parameters	13
2.	Installation of Vacon Option Boards.....	14
2.1	Control cables	15
2.1.1	Cable grounding	16
2.2	Board information sticker	16
3.	Descriptions of Vacon option boards.....	17
3.1	Basic boards OPT-A_	17
3.1.1	OPT-A1.....	18
3.1.2	OPT-A2.....	22
3.1.3	OPT-A3.....	23
3.1.4	OPT-A4.....	24
3.1.5	OPT-A5.....	28
3.1.6	OPT-A7.....	32
3.1.7	OPT-A8.....	38
3.1.8	OPT-A9.....	42
3.1.9	OPT-AL	43
3.1.10	OPT-AE	45
3.1.11	OPT-AN.....	49
3.2	I/O Expander Boards OPT-B_	53
3.2.1	OPT-B1	54
3.2.2	OPT-B2	56

3.2.3	OPT-B4	57
3.2.4	OPT-B5	58
3.2.5	OPT-B8	59
3.2.6	OPT-B9	61
3.2.7	OPT-BB	62
3.3	Adapter Boards OPT-D_	66
3.3.1	OPT-D1	67
3.3.2	OPT-D2	69
3.3.3	OPT-D3	73
3.3.4	OPT-D6	75
4.	Vacon Option Boards – operational details	77

1. GENERAL INFORMATION

Vacon NX range embodies a wide selection of *expander* and *adapter boards* with which the available I/O of Vacon NX frequency converter can be increased and its versatility improved.

The input and output configuration (I/O) of Vacon NX is designed with modularity in mind. The total I/O is comprised of option boards, each having its own input and output configuration. The boards contain not only normal analogue and digital inputs and outputs, but also fieldbuses and additional application-specific hardware.

The basic, expander and adapter boards are placed in the *board slots* on the control board of the frequency converter. The I/O boards are usually interchangeable between different Vacon types, i.e. NXS and NXP. However, the control boards of these types differ from each other to some extent which means that the use of some I/O boards in different Vacon frequency converter types may be restricted.

1.1 Board slots on the control board of Vacon NXS and NXP

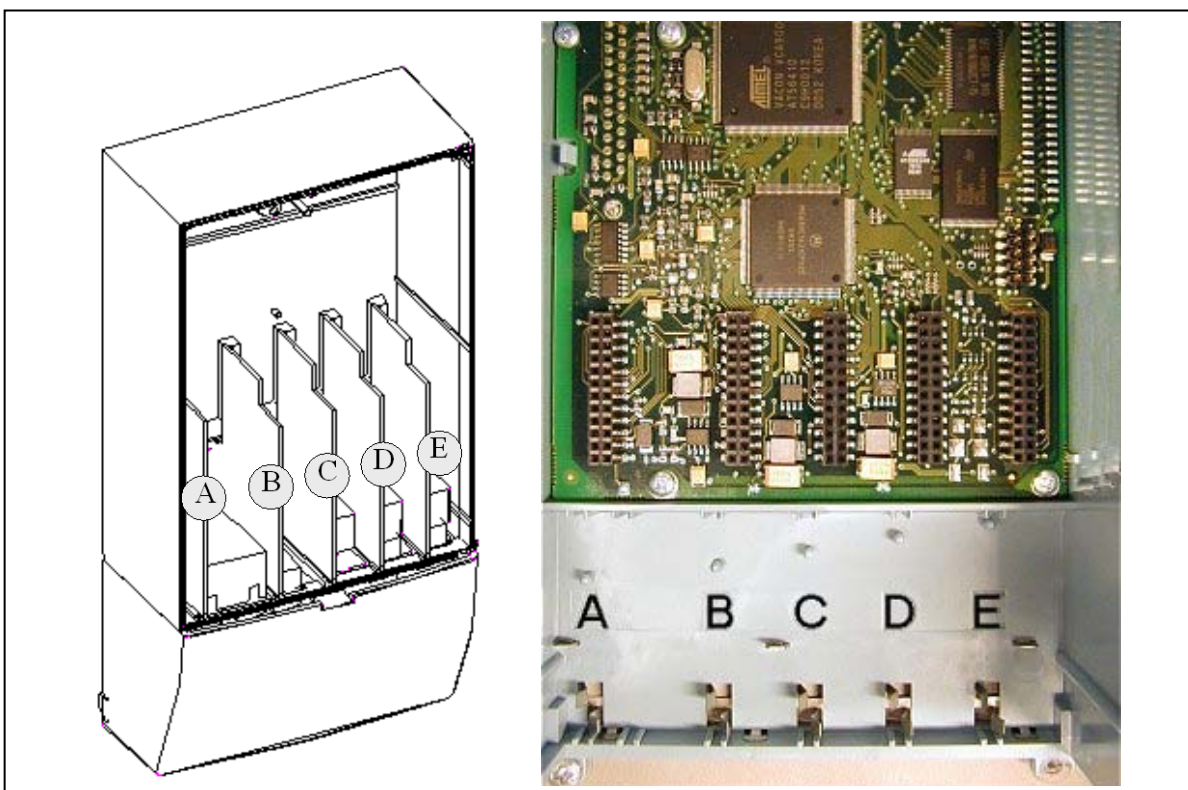

Figure 1-1. Board slots on control board of the Vacon NXS and NXP

The control board is situated inside the *control unit* of the Vacon NX frequency converter. There are **five** board slots (labelled **A** to **E**) on the control board of NXS and NXP (See User's Manual, Chapter 6.2.1): The connectability of different option boards to different slots depends greatly on the type of the board. For more information on this, see Chapter 1.2. See also the descriptions of the options boards on pages 18 to 68.

Usually, when the frequency converter is delivered from the factory, the control unit includes at least the standard compilation of two basic boards (I/O board and relay board) which are normally installed in slots A and B. The I/O boards mounted at the factory are indicated in the type code of the frequency converter. The three expander slots C, D and E are available for different option boards i.e. I/O expander boards, fieldbus boards and adapter boards.

1.2 Board Slots on the control board of Vacon NXL

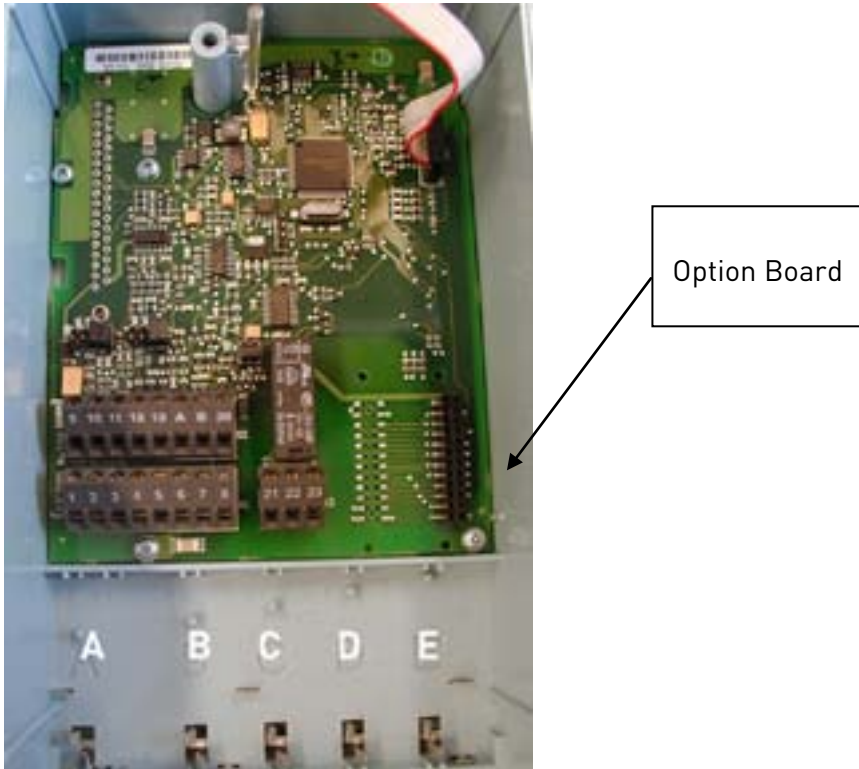

Figure 1-2. Board slots on control board of Vacon NXL.

The control board of NXL includes fixed standard I/O and one place for option boards (see User's Manual of NXL, Chapter 6.2.). The most typical option board for NXL, OPT-AA, is specified in the User's Manual, Chapter 10.

1.3 Option board types

The Vacon option boards are divided in four groups according to their characteristics: types A, B, C and D. Short descriptions of the types below:

OPT-A_

- Basic boards used for basic I/O (NXS, NXP); normally pre-installed at the factory
- This board type uses slots A, B or C.

See pages 17 to 45 for a detailed presentation of the boards of this type. See also the principle diagram on the options boards and their equipment on page 77.

OPT-B_

- Option boards used for I/O expansion
- Normally pluggable into slots B, C, D and E

See pages 46 to 58 for a detailed presentation of the boards of this type. See also the principle diagram on the options boards and their equipment on page 77.

OPT-C_

- Fieldbus boards (e.g. Profibus or Modbus)
- These boards are connected to slots **D** and **E**.

See a separate manual on each individual Fieldbus Board. Ask factory or your nearest distributor for more information.

OPT-D_

- Adapter boards
- Boards with fiber optic adapters, e.g. System Bus Fiber Optic Adapter Board.
- Connect the adapter boards to slots **D** and **E** (see however page 73).

See pages 59 to 68 for a detailed presentation of the boards of this type. See also the principle diagram on the option boards and their equipment on page 69.

1.4 Technical data

The data in the table below applies to the inputs and outputs on all basic and expander boards.

Safety (all boards)	Comply with EN50178, C-UL and EN60204-1 Inputs/outputs galvanically isolated; Isolation voltage rate 500V
Input/output type	Specification
Analogue inputs (AI), voltage	0...±10V, $R_i \geq 200 \text{ k}\Omega$, single-ended; Resolution 10 bits/0.1%, accuracy ±1% of the full display (-10...+10V joystick control)
Analogue inputs (AI), current	0(4)...20mA, $R_i = 250\Omega$, differential Resolution 10 bits/0.1%, accuracy ±1% of the full display
Digital inputs (DI), DC voltage controlled	24V: "0" ≤ 10V, "1" ≥ 18V, $R_i > 5\text{k}\Omega$
Digital inputs (DI), AC voltage controlled	Control voltage 42...240 VAC "0" < 33V, "1" > 35V
Auxiliary voltage (output) (+24V) Auxiliary voltage (input) (ext. +24V)	24V (±15%), max 250mA (total summarized load from ext. +24V outputs, max. 150 mA from one board. 24VDC (±10%, max. ripple voltage 100mV RMS), max. 1A. In special applications where PLC type functions are included in the control unit the input can be used as external auxiliary power supply for control boards as well as I/O boards.
Reference voltage (output) (+10V _{ref})	10V - 0% - +2%, max. 10mA
Analogue output (AO), current (mA)	0(4)...20mA, $R_L < 500\Omega$, resolution 10 bits/0.1%, accuracy ≤ ±2%
Analogue output (AO), voltage (V)	0(2)...10V, $R_L \geq 1\text{k}\Omega$, resolution 10 bits, accuracy ≤ ±2%
Relay outputs (RO)	Switching capacity 24VDC/8A 250VAC/8A 125VDC/0.4A Max. continuous load 2A rms Min. switching load: 5V/10mA
Thermistor input (TI)	$R_{tri0} = 4.7\text{k}\Omega$ (PTC type)
Encoder control voltage (+5V/+12V/ +15V/+24V)	See OPT-A4, OPT-A5, OPT-A7, OPT-AE and OPT-BB technical data
Encoder connections (inputs, outputs)	See OPT-A4, OPT-A5, OPT-A7, OPT-AE and OPT-BB technical data
Environment (all boards)	
Ambient operating temperature	-10...55°C
Storing temperature	-40...60°C
Humidity	<95%, no condensation allowed
Altitude	Ma 1000m
Vibration	0,5 G at 9...200 Hz

Table 1-1. Technical data

1.4.1 Isolation

The control connections are isolated from the mains potential and the I/O ground is connected directly to the frame of the frequency converter. Digital inputs and relay outputs are isolated from the I/O ground. For digital input arrangements, see Chapter *Digital input signal conversions* on page 8.

1.4.2 Analogue inputs (mA/V)

Analogue inputs of I/O boards can be used as either current inputs or voltage inputs (see detailed description of each board). The signal type is selected with a jumper block on the board. In case the voltage type input is used you still have to define the voltage range with another jumper block. The factory default value for the analogue signal type is given in the description of the board. For detailed information, see the description of the board in question.

1.4.3 Analogue outputs (mA/V)

In the same way as in the analogue inputs, the output signal type (current/voltage) can be selected with jumper except for some expander boards with analogue outputs used only with current signals.

1.4.4 Control voltage (+24V/EXT+24V)

The control voltage output +24V/EXT+24V can be used in two ways. Typically, the +24V control voltage is wired to digital inputs through an external switch. The control voltage can also be used to power-up external equipment, such as encoders and auxiliary relays.

Observe that the specified **total** load on all available +24V/EXT+24V output terminals may not exceed 250mA. The maximum load on the +24V/EXT+24V output **per board** is 150mA. See *Figure 1-3*.

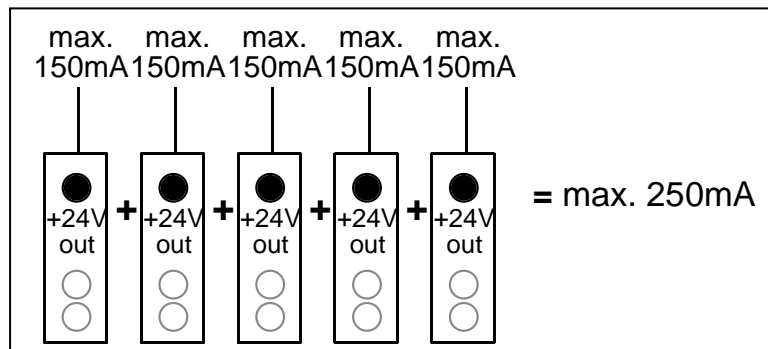

Figure 1-3. Maximum loads on +24V/EXT+24V output

The +24V/EXT+24V outputs can further be used to externally power-up the control board as well as the basic and expander boards. If an external power supply is connected to EXT+24V output, the control board, basic boards and expander boards remain live even if mains should be lost on the frequency converter. This ensures sufficient functioning of the control logic (not the motor control, however) and some alarms in exceptional power-loss situations. Furthermore, fieldbus links remain powered which enables e.g. the Profibus Master to read valuable data on the frequency converter.

Note: The power unit is not powered through the EXT+24V and therefore the motor control does not work if the mains is lost.

Requirements for an external power back-up:

- output voltage +24DC±10%, max. ripple voltage 100mV RMS
- max. current 1A
- 1A external fuse (no internal short-circuit protection on the control board)

Note: Analogue outputs and inputs do not work with only +24V supplied to the control unit.

If there is a +24V/EXT+24V output on the board it is short-circuit protected locally. Should one of the +24V/EXT+24V outputs short-circuit, the others would remain powered because of the local protection.

1.4.5 Digital input signal conversion

The active signal level depends on which potential the common input CMA (and CMB if available) is connected to. The alternatives are +24V or Ground (0V). See *Figure 1-4*, *Figure 1-5* and *Figure 1-6*.

The 24-volt control voltage and the ground for the digital inputs and the common input (CMA) can be either internal or external.

Some typical input signal conversion examples are shown below. If you use the internal +24V from the frequency converter, the following arrangements are possible:

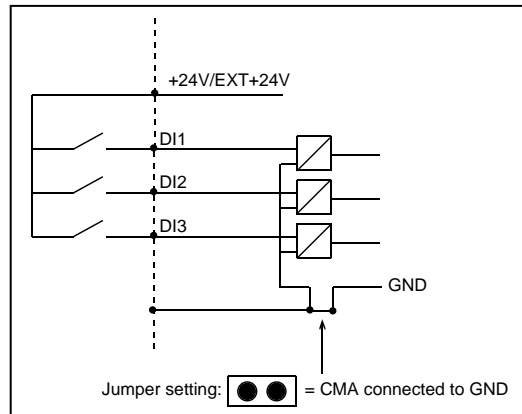

Figure 1-4. If CMA is connected to GND with inboard jumper the internal +24V is used and the CMA terminal ed not be wired

If you use an external +24V the following arrangements are possible:

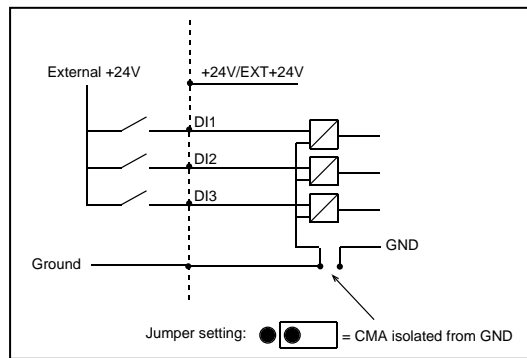

Figure 1-5. Positive logic with external +24V when CMA is isolated from GND using onboard jumper. The input is active when the switch is closed.

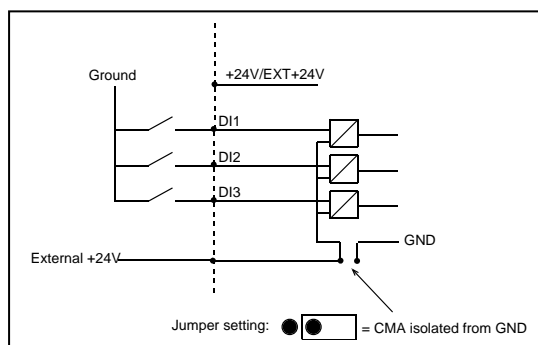

Figure 1-6. Negative logic with external +24V when CMA is isolated with onboard jumper. The input is active when the switch is closed (0V is the active signal).

You can make the positive and negative logic arrangements also with the internal +24V. Place the jumper block in the 'CMA isolated from GND' position (as above) and wire the CMA terminal to the GND terminal of the frequency converter.

1.5 Hardware protections

1.5.1 Terminal block coding

In order to avoid incorrect connections of terminal blocks to boards, some terminal blocks as well as related terminal connectors on the board are uniquely coded. For more information, see the description of the individual board.

1.5.2 Board slot guides and allowed slots

You cannot mount an option board into any slot. Table 4-1 and Table 4-2 show which slots are allowed for which option boards. For reasons of safety, slots A and B are protected in hardware against mounting of unallowed boards. As regards mounting of unallowed boards into slots C, D and E, the boards just will not work, there is no danger of health or equipment damage.

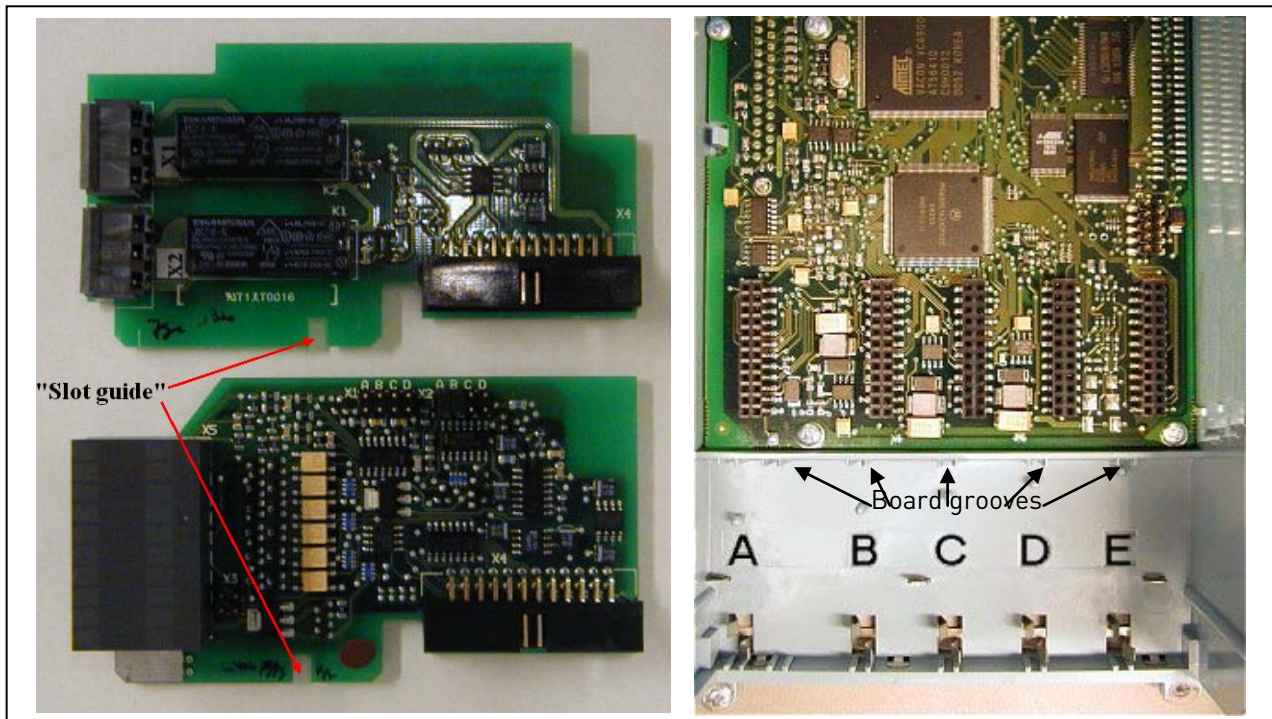

Figure 1-7. Board guide to prevent incorrect mountings

1.6 Type identification number

Note: This information is relevant only for special applications designers using the Vacon NC1131-3 engineering tool.

Each Vacon OPTxx board has a unique type designation code. Besides the type designation code, each board has a unique Type identification number which is used by the system program to identify which board is plugged into which board slot. The system program and the application use the Type ID also to establish the needed connections in order to achieve the desired functionality of the available I/O boards in the control unit. The ID code is loaded in the memory of the board.

1.7 Defining functions to inputs and outputs

How to connect functions and the available I/O depends on the application you use. The Vacon All in One Application Package includes seven applications: *Basic Application*, *Standard Application*, *PID Control Application*, *Multi-Step Speed Control Application*, *Local/Remote Control Application*, *Pump and Fan Control Application with Autochange* and *Multipurpose Control Application* (see Application

Manuals). All but two applications of these use the conventional Vacon method to connect functions and the I/O. In the *Function to Terminal Programming Method (FTT)*, you have a fixed input or output that you define a certain function for. The mentioned two applications, **Pump and Fan Control** and **Multipurpose Control Application**, however, use the *Terminal to Function Programming Method (TTF)* in which the programming process is carried out the other way round: Functions appear as parameters which the operator defines a certain input/output for.

Connecting a certain input or output to a certain function (parameter) is done by giving the parameter an appropriate value, the *address code*. The code is formed of the *Board slot* on the Vacon NX control board (see page 4 and 5) and the *respective input/output number*. See below.

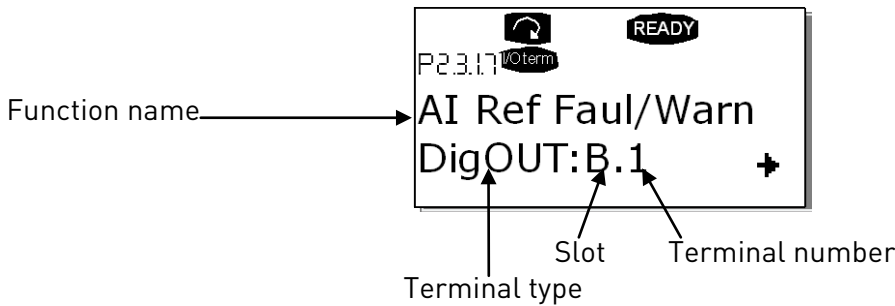

Example: You use the Pump and Fan Control Application. You want to connect the digital output function Reference fault/warning (parameter 2.3.1.7) to the digital output DO1 on the basic board OPT-A1.

First find the parameter 2.3.1.7 on the keypad. Press the *Menu button right* once to enter the edit mode. On the *value line*, you will see the terminal type on the left (DigIN, DigOUT, An.IN, An.OUT) and on the right, the present input/output the function is connected to (B.3, A.2 etc.), or if not connected, a code 0.#.

When the value is blinking, hold down the *Browser button up* or *down* to find the desired board slot and input/output number. The program will scroll the board slots starting from 0 and proceeding from A to E and the I/O numbers from 1 to 10.

Once you have set the desired code, press the *Enter button* once to confirm the change.

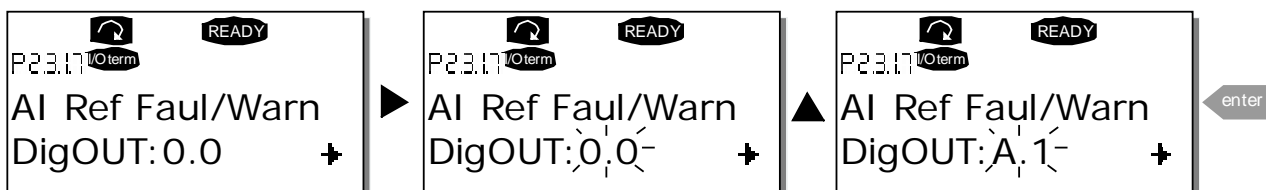

1.8 Defining a terminal for a certain function with NCDrive programming tool

If you use the NCDrive Programming Tool for parametrizing you will have to establish the connection between the function and input/output in the same way as with the control panel. Just pick the address code from the drop-down menu in the *Value* column (see *Figure 1-8* below).

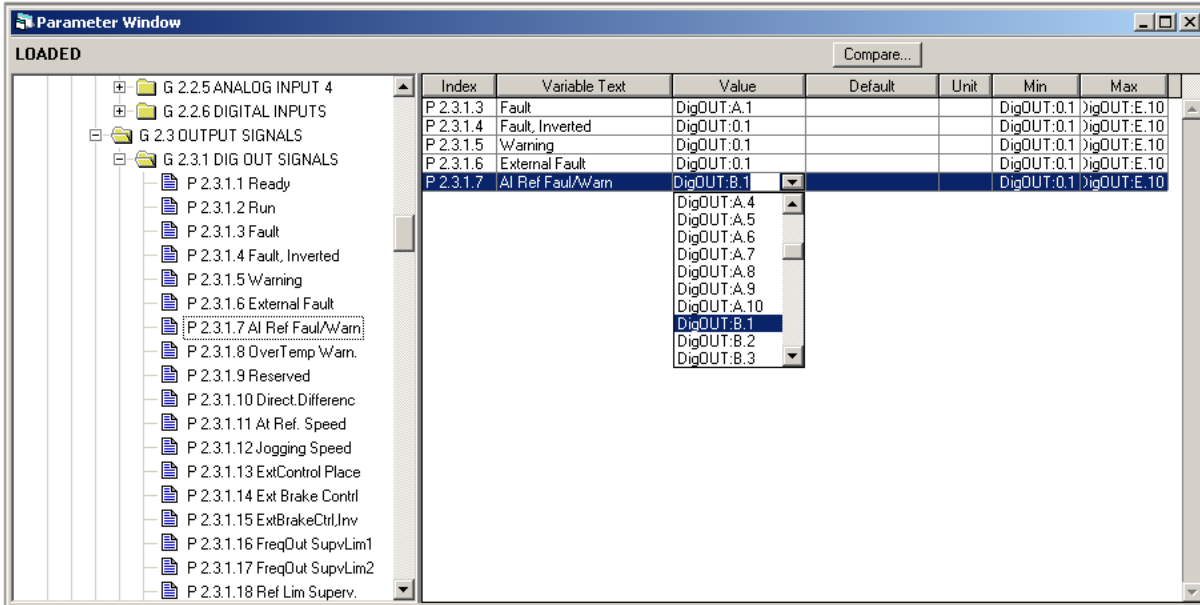



Figure 1-8. Screenshot of NCDrive programming tool; Entering the address code

 WARNING	<p>Be ABSOLUTELY sure not to connect two functions to one and same output in order to avoid function overruns and to ensure flawless operation.</p>
---	---

Note: The *inputs*, unlike the *outputs*, cannot be changed in RUN state.

1.9 Option board related parameters

Some of the input and output functions of certain option boards are controlled with associated parameters. The parameters are used to set the signal ranges for analogue inputs and outputs as well as values for different encoder functions.

The board-related parameters can be edited in the *Expander Board Menu (M7)* of the control keypad.

Enter the following menu level (**G#**) with the Menu button right. At this level, you can browse through slots A to E with the Browser buttons to see what expander boards are connected. On the lowermost line of the display you also see the number of parameters associated with the board. Edit the parameter value as shown below. For more information on the keypad operation, see Vacon NX User's Manual, Chapter 7. See *Figure 1-9*.

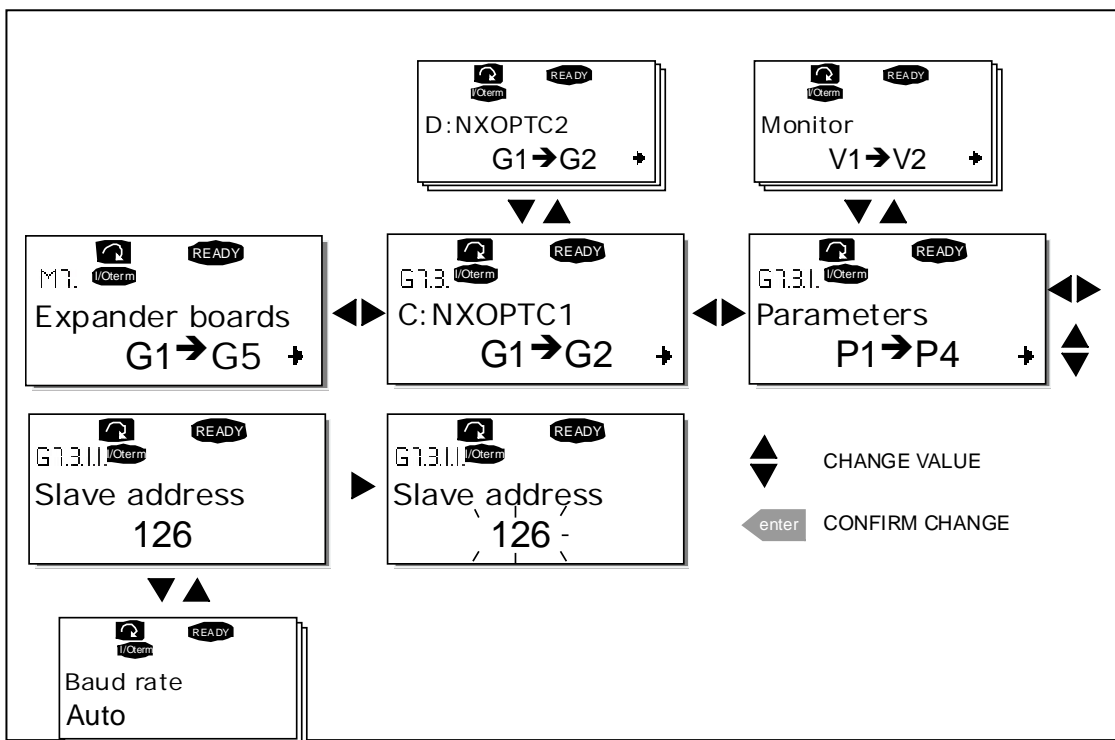





Figure 1-9. Board parameter value editing

Note: Fieldbus boards (OPT-C_) also have fieldbus-related parameters. These boards are, however, described in the separate fieldbus board manuals (please visit <http://www.vacon.com/support/documents.html>).

2. INSTALLATION OF VACON OPTION BOARDS

 NOTE	<p>It is not allowed to add or replace option boards or fieldbus boards on a frequency converter with the power switched on. This may damage the boards.</p>
--	---

<p>A</p>	<p>Vacon NX frequency converter</p>	
<p>B</p>	<p>Remove the cable cover.</p>	
<p>C</p>	<p>Open the cover of the control unit.</p>	

Continues on next page

D Install the option board in a correct slot on the control board of the frequency converter. On attaching (also removing) the board, hold it in horizontally straight position to avoid twisting the connector pins. See the photos below.

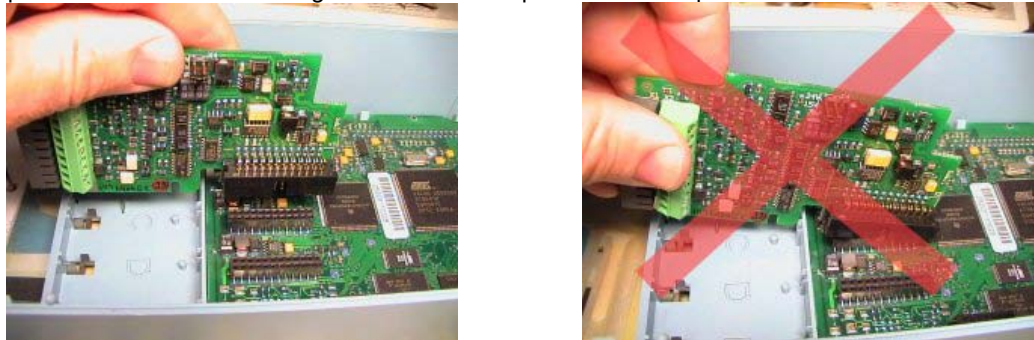

Make sure that the board (see below) fits tightly in the metal clamp and the plastic groove. If the board seems to be difficult to fit in the slot you may have to check the allowed slots for your option board.

Note: Check that the jumper settings on the board correspond to you needs. Finally, close the cover of the frequency converter and the cable cover.

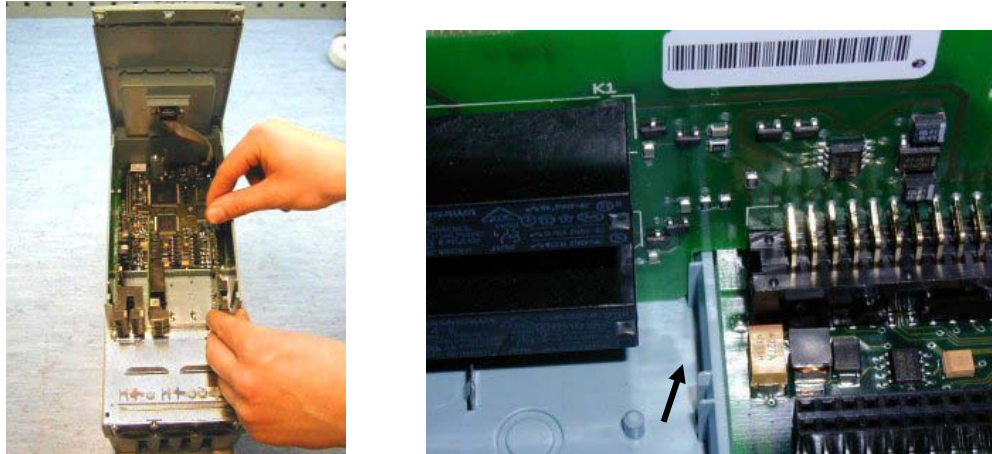

2.1 Control cables

The control cables used shall be at least 0.5mm² screened multicore cables. The maximum terminal wire size is 2.5mm² for the relay terminals and 1.5 mm² for other terminals.

Find the tightening torques of the option board terminals in the table below.

Terminal screw	Tightening torque	
	Nm	lb-in.
Relay and thermistor terminals (screw M3)	0.5	4.5
Other terminals (screw M2.6)	0.2	1.8

Table 2-1. Tightening torques of terminals

Cable type	Level H, C	Level L
Control cable	4	4

Table 2-2. Cable types required to meet standards.

Level H = EN 61800-3+A11, 1st environment, restricted distribution
EN 61000-6-4

Level L = EN61800-3, 2nd environment

4 = Screened cable equipped with compact low-impedance shield (NNCABLES /Jamak, SAB/ÖZCuY-O or similar).

2.1.1 Cable grounding

We recommend to ground the control cables in the manner presented above.

Strip the cable at such distance from the terminal that you can fix it to the frame with the grounding clamp.

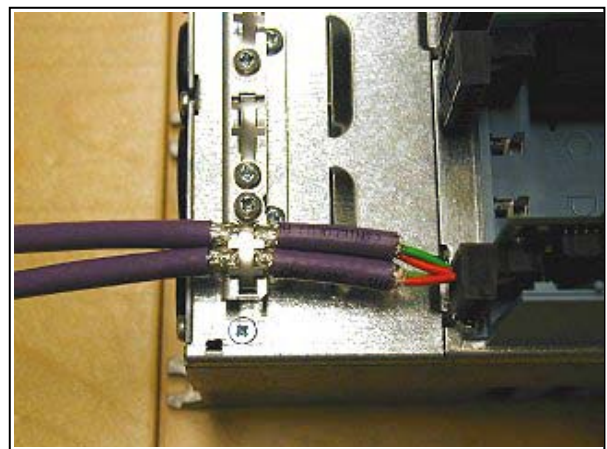
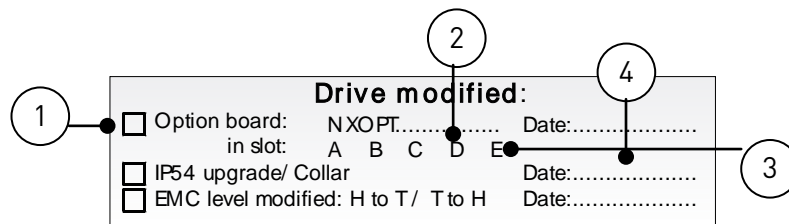

Figure 2-1. Grounding of control cable

2.2 Board information sticker

Each I/O option board package delivered by the factory includes a sticker (shown below) where possible modifications made in the frequency converter are noted. Please check *Option board* (1), mark the board type (2), the slot into which the board is mounted (3) and the mounting date (4) on the sticker. Finally, attach the sticker on your drive.



3. DESCRIPTIONS OF VACON OPTION BOARDS

3.1 Basic boards OPT-A_

- Basic boards used for basic I/O; normally pre-installed at the factory
- This board type uses slots **A**, **B** and **C**.

The standard Vacon NXS and NXP frequency converters contain two boards placed in slots A and B. The board in slot A (OPT-A1, OPT-A8 or OPT-A9) has digital inputs, digital outputs, analogue inputs and an analogue output. The board in slot B (OPT-A2) has two change-over relay outputs. As an alternative to OPT-A2, a board of type OPT-A3 can also be placed in slot B. In addition to the two relay outputs, this board has one thermistor input.

The boards you wish to have installed in your frequency converter have to be defined in the type designation code of the frequency converter when ordering it from the factory.

FC type	I/O board	Allowed slots	DI	DO	AI	AO	RO	TI	Other
NXS NXP	OPT-A1	A	6	1	2 (mA/V), incl. -10...+10V	1 (mA/V)			+10Vref +24V/ EXT+24V
NXS NXP	OPT-A2	B					2 (NO/NC)		
NXS NXP	OPT-A3	B					1 (NO/NC) + 1 NO	1	
NXS ¹⁾ NXP	OPT-A4	C	3 DI encoder (RS-422) + 2 DI (qualifier & fast input)						+5V/+15V/+24V (progr.)
NXS ¹⁾ NXP	OPT-A5	C	3 DI encoder (wide range) + 2 DI (qualifier & fast input)						+15V/+24V (progr.)
NXP	OPT-A7	C	6 (enc.)	2 (enc.)					+15V/+24V (progr.)
NXS NXP	OPT-A8	A	6	1	2 (mA/V), incl. -10...+10V (de-coupled from GND)	1 (mA/V) (decoupled from GND)			+10Vref (decoupled from GND) +24V/ EXT+24V
NXS NXP	OPT-A9	A	6	1	2 (mA/V), incl. -10...+10V	1 (mA/V)			+10ref (2,5 mm terminals) +24V/ EXT+24V
NXS ¹⁾ NXP	OPT-AE	C	3 DI encoder (wide range)	2 (Enc.)					+15V/+24V (progr.)
NXS NXP	OPT-AL	A	6 42...240 VAC	1	2 (AI1 0-10V) (AI2 +-10V)	2 (AO1 mA) (AO2 V)			+15V/+24V
NXP	OPT-AN	A	6		2 (mA/V), incl. -10...+10V	2 (mA/V), incl. -10...+10V			+10Vref -10Vref +24V/ EXT+24V

Table 3-1. Vacon NX Basic boards and their equipment

¹⁾ Encoder board can be used in Vacon NXS with special applications only.

DI = Digital input
AI = Analogue input

DO = Digital output
AO = Analogue output

TI = Thermistor input
RO = Relay output

3.1.1 OPT-A1

OPT-A1

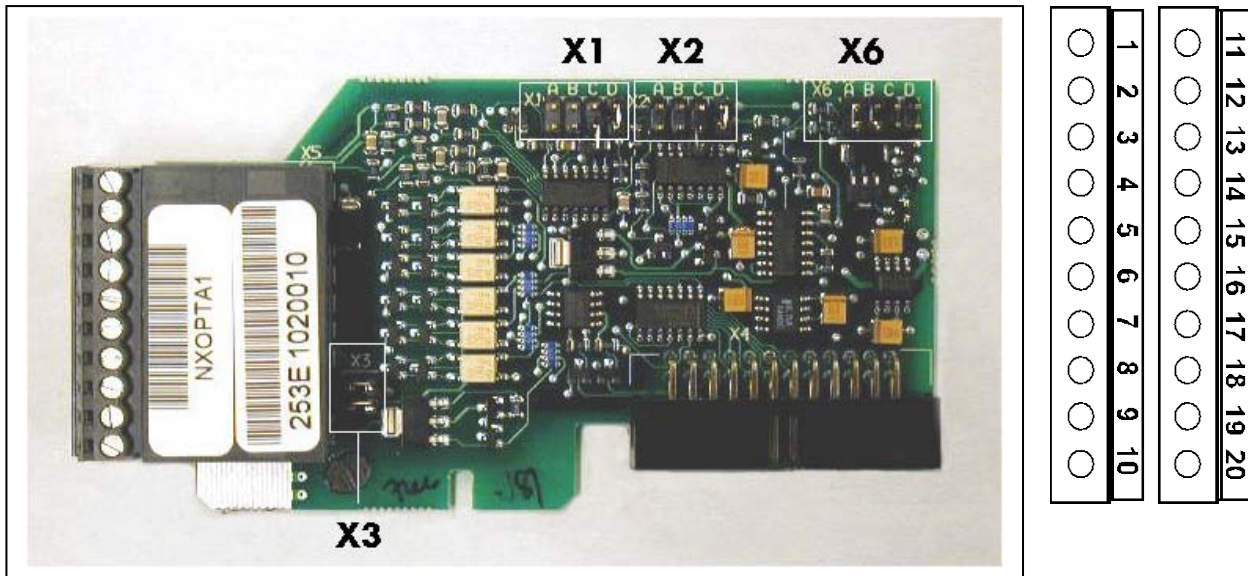

Figure 3-1. Vacon OPT-A1 option board

- Description:* Standard I/O board with digital inputs/outputs and analogue inputs/outputs
- Allowed slots:* A
- Type ID:* 16689
- Terminals:* Two terminal blocks (coded = mounting of blocks in wrong order prevented, terminals #1 and #12);
Screw terminals (M2.6)
- Jumpers:* 4; X1, X2, X3 and X6 (See Figure 3-2.)
- Board parameters:* Yes (see page 21)

I/O terminals on OPT-A1 (coded terminals painted black)

Terminal	Parameter reference on keypad and NCDrive	Technical information
1	+10 Vref	Reference output +10V; Maximum current 10 mA
2	AI1+	An.IN:A.1 Selection V or mA with jumper block X1 (see page 20): Default: 0- +10V (R _i = 200 kΩ) (-10V..+10V Joy-stick control, selected with a jumper) 0- 20mA (R _i = 250 Ω) Resolution 0.1%; Accuracy ±1%
3	AI1-	
4	AI2+	An.IN:A.2 Selection V or mA with jumper block X2 (see page 20): Default: 0- 20mA (R _i = 250 Ω) 0- +10V (R _i = 200 kΩ) (-10V..+10V Joy-stick control, selected with a jumper) Resolution: 0.1%; Accuracy ±1%
5	AI2-	
6	24 Vout (bi-directional)	24V auxiliary voltage output. Short-circuit protected. ±15%, maximum current 150 mA, see 1.4.4 +24Vdc external supply may be connected. Galvanically connected to terminal #12.
7	GND	
8	DIN1	DigIN:A.1
9	DIN2	DigIN:A.2
10	DIN3	DigIN:A.3
11	CMA	Digital input common A for DIN1, DIN2 and DIN3. Connection by default to GND. Selection with jumper block X3 (see page 20):
12	24 Vout (bi-directional)	Same as terminal #6 Galvanically connected to terminal #6.
13	GND	Same as terminal #7 Galvanically connected to terminals #7 and 19
14	DIN4	DigIN:A.4
15	DIN5	DigIN:A.5
16	DIN6	DigIN:A.6
17	CMB	Digital input common B for DIN4, DIN5 and DIN6. Connection by default to GND. Selection with jumper block X3 (see page 20):
18	A01+	AnOUT:A.1 Analogue output Output signal range: Current 0(4)-20mA, R _L max 500Ω or Voltage 0-10V, R _L >1kΩ Selection with jumper block X6 (see page 20): Resolution: 0.1% (10 bits); Accuracy ±2%
19	A01-	
20	D01	DigOUT:A.1 Open collector output Maximum U _{in} = 48VDC Maximum current = 50 mA

OPT-A1

Table 3-2. OPT-A1 I/O terminals

Jumper selections

There are four jumper blocks on the OPT-A1 board. The factory defaults and other available jumper selections are presented below.

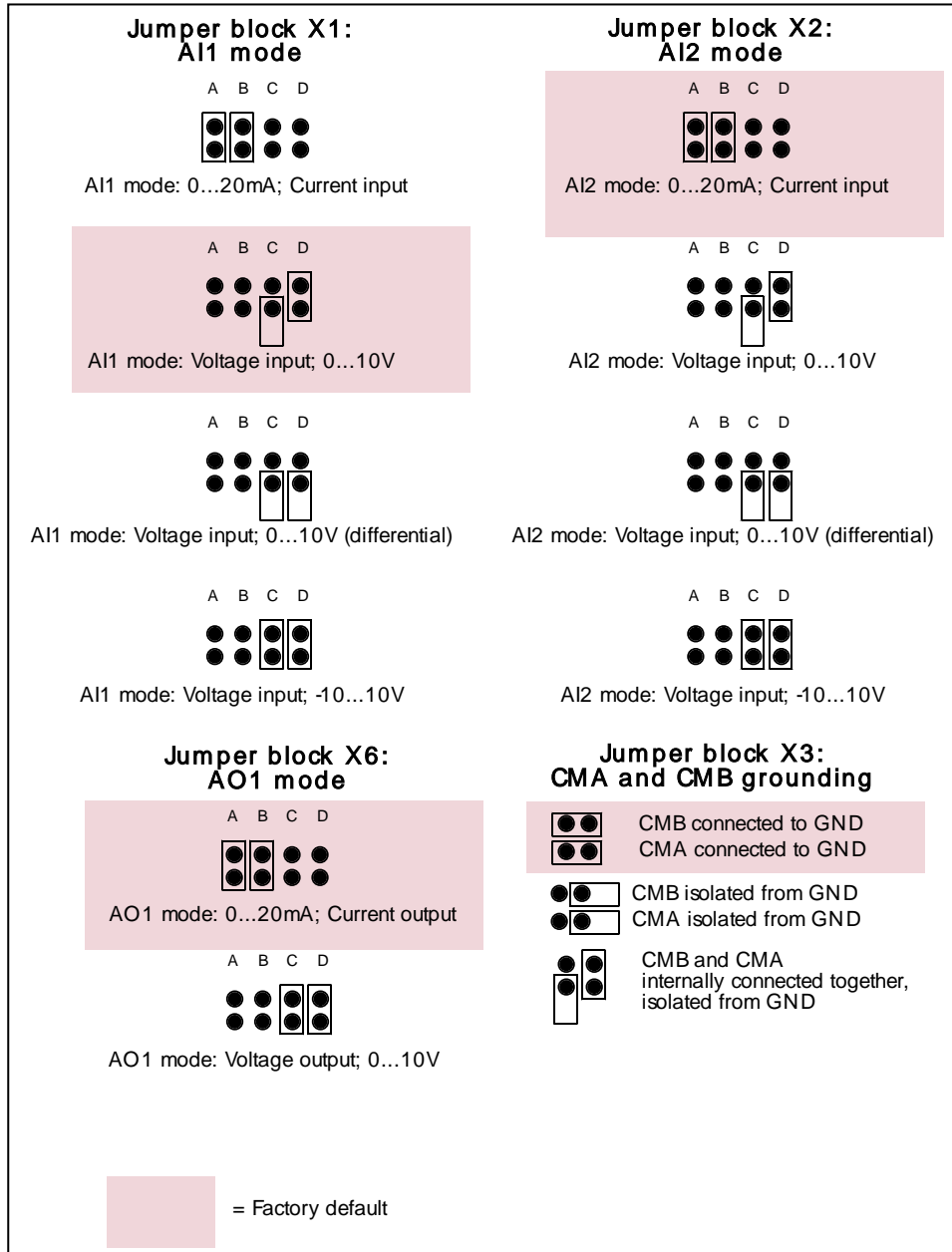

Figure 3-2. Jumper block selection on OPT-A1

OPT-A1 parameters

Number	Parameter	Min	Max	Default	Note
1	AI1 mode	1	5	3	1 = 0...20mA 2 = 4...20mA 3 = 0...10V 4 = 2...10V 5 = -10...+10V
2	AI2 mode	1	5	1	1 = 0...20mA 2 = 4...20mA 3 = 0...10V 4 = 2...10V 5 = -10...+10V
3	AO1 mode	1	4	1	1 = 0...20mA 2 = 4...20mA 3 = 0...10V 4 = 2...10V

Table 3-3. OPT-A1 board-related parameters

OPT-A1

3.1.2 OPT-A2

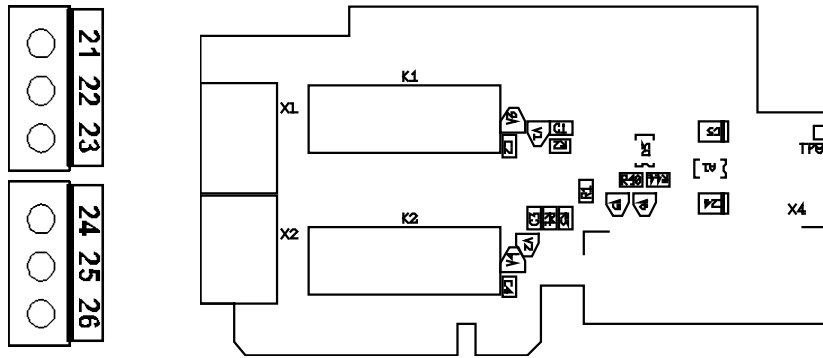

Description: Standard Vacon NX frequency converter relay board with two relay outputs
Allowed slots: B
Type ID: 16690
Terminals: Two terminal blocks; Screw terminals (M3); No coding
Jumpers: None
Board parameters: None

I/O terminals on OPT-A2

Terminal		Parameter reference on keypad and NCDrive	Technical information	
21	R01/normal closed	DigOUT:B.1	Relay output 1 (NO/NC)	
22	R01/common		Switching capacity	24VDC/8A
23	R01/normal open			250VAC/8A
			Min. switching load	125VDC/0.4A
				5V/10mA
24	R02/normal closed	DigOUT:B.2	Relay output 2 (NO/NC)	
25	R02/common		Switching capacity	24VDC/8A
26	R02/normal open			250VAC/8A
			Min. switching load	125VDC/0.4A
				5V/10mA

Table 3-4. OPT-A2 I/O terminals

3.1.3 OPT-A3

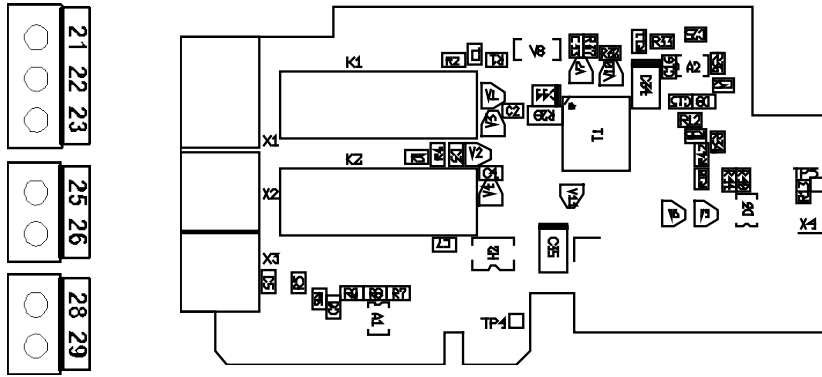

Description: Relay board with two relay outputs and one thermistor input for Vacon NX frequency converter

Allowed slots: B

Type ID: 16691

Terminals: Three terminal blocks; Screw terminals (M3); No coding.

Jumpers: None

Board parameters: None

I/O terminals on OPT-A3

Terminal		Parameter reference on keypad and NCDrive	Technical information	
21	R01/normal closed	DigOUT:B.1	Relay output 1 (NO/NC)	
22	R01/common		Switching capacity	24VDC/8A
23	R01/normal open			250VAC/8A 125VDC/0.4A
			Min. switching load	5V/10mA
25	R02/common	DigOUT:B.2	Relay output 2 (NO)	
26	R02/normal open		Switching capacity	24VDC/8A
				250VAC/8A 125VDC/0.4A
			Min. switching load	5V/10mA
28	T11+	DigIN:B.1	Thermistor input; $R_{trip} = 4.7 \text{ k}\Omega$ (PTC)	
29	T11-			

Table 3-5. OPT-A3 I/O terminals

3.1.4 OPT-A4

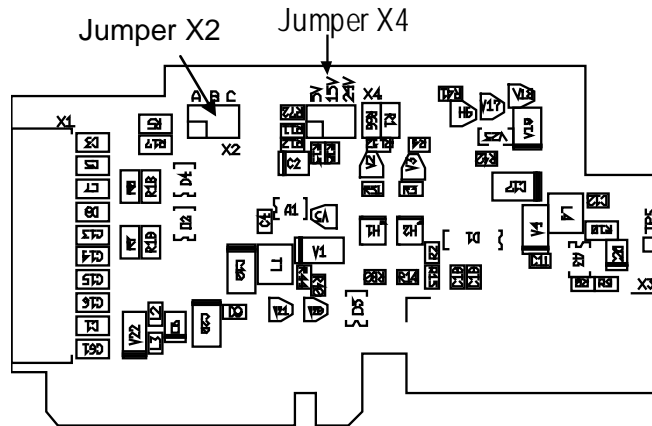
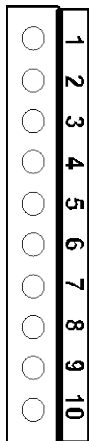

OPT-A4

Description:

Encoder board for **Vacon NXP**. Encoder input board with programmable control voltage for an encoder

The encoder board OPT-A4 is for TTL type encoders (TTL, TTL(R)) providing input signal levels that meet the RS_422 interface standard. Encoder inputs A, B and Z are not galvanically isolated. The OPT-A4 board includes, too, the qualifier input ENC1Q (meant to trace the Z-pulse in certain situations) and a special/fast digital input DIC4 (used to trace very short pulses). These two inputs are used in special applications.

The TTL type encoders do not have an internal regulator and use therefore a supply voltage of +5V±5% whereas the TTL(R) type encoders have an internal regulator and the supply voltage can be e.g. +15V±10% (depending on the encoder manufacturer).

Allowed slots:

C

Type ID:

16692

Terminals:

One terminal block; Screw terminals (M2.6); Coding in terminal #3.

Jumpers:

2; X4 and X2 (see page 25)

Board parameters:

Yes (see page 26)

I/O terminals on OPT-A4 (coded terminal painted black)

Terminal	Parameter reference Keypad/NCDrive	Technical information
1	DIC1A+	Pulse input A
2	DIC1A-	
3	DIC2B+	Pulse input B; phase shift of 90 degrees compared to Pulse input A
4	DIC2B-	
5	DIC3Z+	Pulse input Z; one pulse per revolution
6	DIC3Z-	
7	ENC1Q	Reserved for future use
8	DIC4	Reserved for future use
9	GND	Ground for control and inputs ENC1Q and DIC4
10	+5V/+15V/+24V	Control voltage (auxiliary voltage) output to encoder; Output voltage selectable with jumper X4. See chapter 1.4.4

Table 3-6. OPT-A4 I/O terminals

Technical data:

Encoder control voltage, +5V/+15V/+24V	Control voltage selectable with jumper X4.
Encoder input connections, inputs A+, A-, B+, B-, Z+, Z-	Max. input frequency ≤150kHz Inputs A, B and Z are differential Encoder inputs are RS-422 interface compatible Max. load per encoder input $I_{low} = I_{high} \approx 25mA$
Qualifier input ENC1Q	Max. input frequency ≤10kHz
Fast digital input DIC4	Min. pulse length 50µs Digital input 24V; $R_i > 5k\Omega$ Digital input is single-ended; connected to GND

Jumper selections

On the OPT-A4 board, there are two jumper blocks. The jumper X2 is used to define the status of the termination resistor ($R=135\Omega$). The jumper X4 is used to program the control voltage (auxiliary voltage). The factory default and other available jumper selections are presented below.

**Jumper block X4:
Auxiliary voltage level**

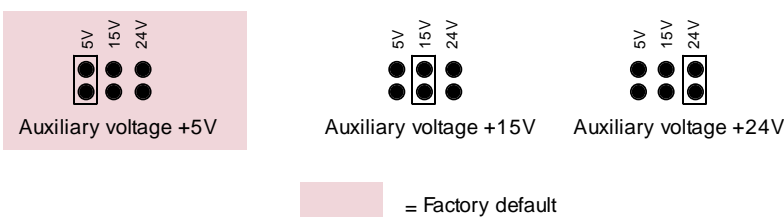

**Jumper block X2:
Termination resistor**

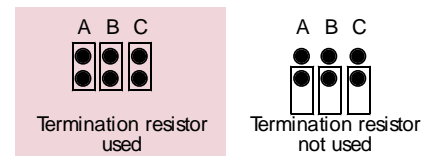

NOTE: If one encoder is connected to one drive only, the termination resistor on the board must be used. If the encoder is connected to several drives, the termination resistor of the last drive must be used.

Encoder connection – Differential

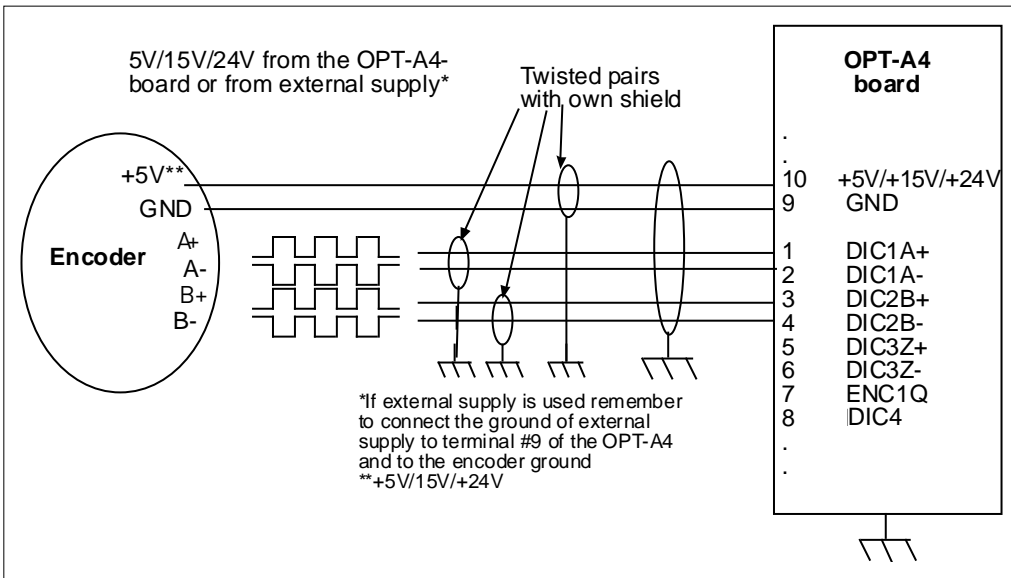
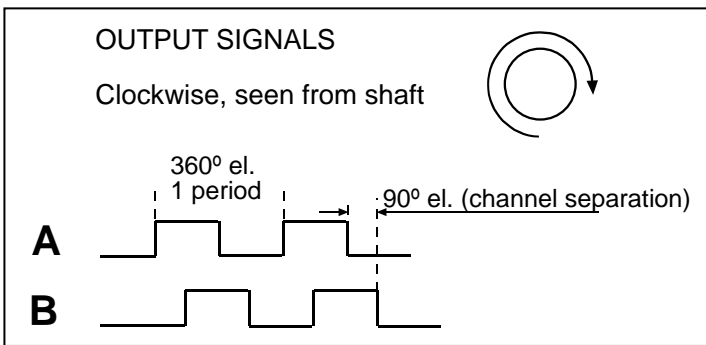

Figure 3-3. RS-422 type encoder connection using differential inputs

Note:

The encoder pulses are handled by Vacon software as presented below:



OPT-A4 parameters

Number	Parameter	Min	Max	Default	Note
7.3.1.1	Pulse/revolution	1	65535	1024	
7.3.1.2	Invert direction	0	1	0	0 = No 1 = Yes
7.3.1.3	Reading rate	0	4	1	Time used to calculate speed actual value. Note: Use value 1 in Closed Loop mode. 0 = No 1 = 1 ms 2 = 5 ms 3 = 10 ms 4 = 50 ms
7.3.1.4	Encoder type	1	3	1	1 = A,B = speed 2 = A = REF, B = DIR 3 = A= FORW, B = REV

Table 3-7. OPT-A4 board-related parameters

Par 7.3.1.4 Encoder Type (can be selected with boards A4, A5 and A7 (encoder 2 mode))

1 = A,B=Speed

Only with this input type it is possible to use Closed Loop speed control in an NXP drive. NXS drives do not have Closed Loop possibility, but encoder signal can be used e.g. for reference or positioning.

This input mode requires that both channels A and B are receiving pulses, differential connection is recommended.

Direction of speed is determined from 90° difference in signals.

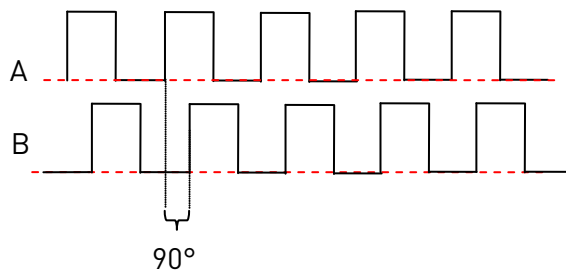

2 = A=Ref,B=Dir

This type can not be used for Closed Loop control!

In this mode only channel A is receiving pulses. Channel B will determine if direction is negative or positive. Input in channel B must be static signal.

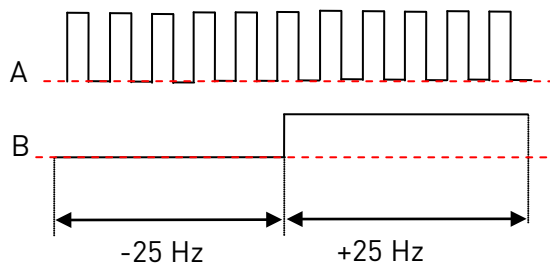

3 = A=Forw, B=Rev

This type can not be used for Closed Loop control!

In this mode both channels are receiving signal but not at the same time.

Pulses on channel A means positive direction.

Pulses on channel B means negative direction.

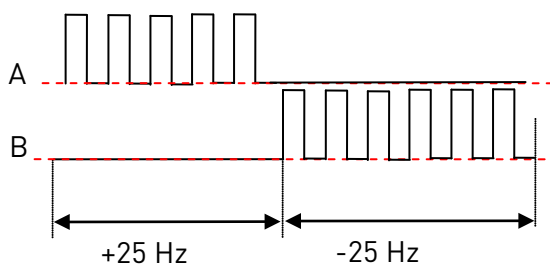

3.1.5 OPT-A5

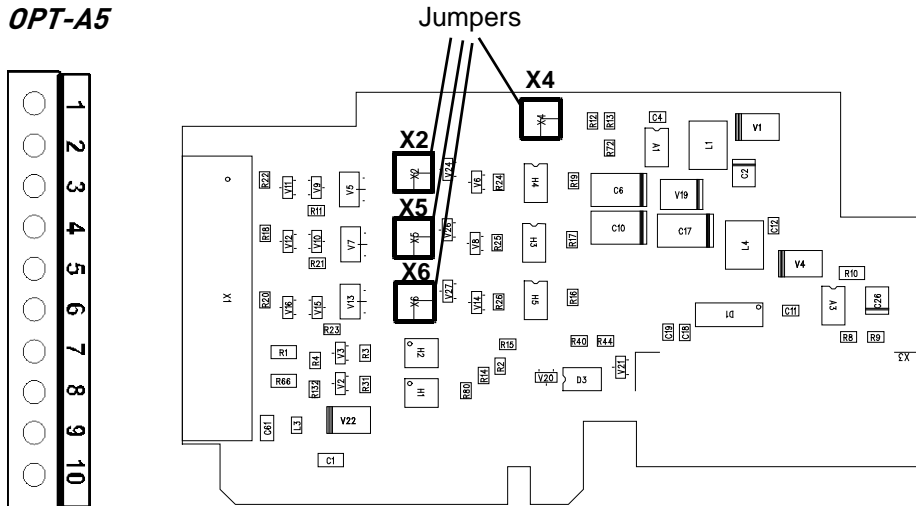

Description:

Encoder board for **Vacon NXP**. Encoder input board with programmable control voltage for an encoder.

The OPT-A5 board is designed for HTL (High voltage Transistor Logic) type encoders (voltage output type push-pull HTL, open collector output type HTL) which provide input signal levels dependent on the supply voltage of the encoder. The encoder inputs A, B and Z are galvanically isolated. The OPT-A5 board includes, too, the qualifier input ENC1Q (meant to trace the Z-pulse in certain situations) and a fast digital input DIC4 (used to trace very short pulses). These two inputs are used in special applications.

The OPT-A5 is similar to the OPT-A4 in connections but the encoder inputs A, B and Z have different signal levels (voltage level). The input levels for A, B and Z of the OPT-A4 are compatible with RS-422 while those of the OPT-A5 are more general wide range inputs. Inputs ENC1Q and DIC4 are identical in both boards.

Allowed slots:

C

Type ID:

16693

Terminals:

One terminal block; Screw terminals (M2.6); Coding in terminal #3.

Jumpers:

4; X2, X4, X5, X6 (see page 30)

Board parameters:

Yes (see page 26)

I/O terminals on OPT-A5 (coded terminal painted black)

Terminal		Parameter reference Keypad/NCDrive	Technical information
1	DIC1A+		Pulse input A (differential); Voltage range 10...24V
2	DIC1A-		
3	DIC2B+		Pulse input B; phase shift of 90 degrees compared to Pulse input A (differential); Voltage range 10...24V
4	DIC2B-		
5	DIC3Z+		Pulse input Z; one pulse per revolution (differential); Voltage range 10...24V
6	DIC3Z-		
7	ENC1Q		Reserved for future use
8	DIC4		Reserved for future use
9	GND		Ground for control and inputs ENC1Q and DIC4
10	+15V/+24V		Control voltage (auxiliary voltage) output to encoder; Output voltage selectable with jumper X4. See chapter 1.4.4.

Table 3-8. OPT-A5 I/O terminals

Note: Encoder inputs are wide range inputs that can be used with encoders using +15V or +24V

Technical data:

Encoder control voltage, +15V/+24V	Control voltage selectable with jumper X4.
Encoder input connections, inputs A+, A-, B+, B-, Z+, Z-	Max. input frequency ≤150kHz Inputs A, B and Z are differential
Qualifier input ENC1Q	Max. input frequency ≤10kHz
Fast digital input DIC4	Min. pulse length 50µs Digital input 24V; R _i >5kΩ Digital input is single-ended; connected to GND

Note: A high pulse frequency combined with a great cable capacitance places a considerable load on the encoder. Apply therefore as low a voltage as possible for the encoder supply, rather lower than 24V. The manufacturer also recommends to place jumper X4 to position +15V, if allowed in the voltage range specification of the encoder.

Jumper selections

On the OPT-A5 board, there are four jumper blocks; X4 is used to program the control voltage (auxiliary voltage), X2, X5 and X6 are set according the voltage of the encoder. The factory default and other available jumper selections are presented below.

**Jumper block X4:
Auxiliary voltage level**

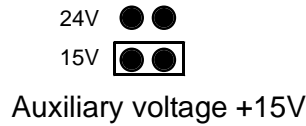
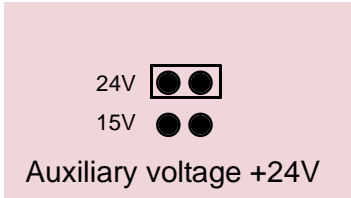

**Jumper blocks X2, X5 and X6:
encoder voltage level**



= Factory default

Jumper blocks X2, X5 and X6:

When these jumpers are set to High (default and typically good for 24V encoders), it means that when the voltage at the channel goes above 8V, it will acknowledge a new pulse.

When they are set to Low = 2.3 V, it means that when the voltage at the channel goes above 2.3V, it will acknowledge a new pulse.

Usage: Closed Loop Vector Control. The OPT-A5 board is mainly used in conventional industrial applications where encoder cable lengths are relatively long.

Encoder connection – Differential

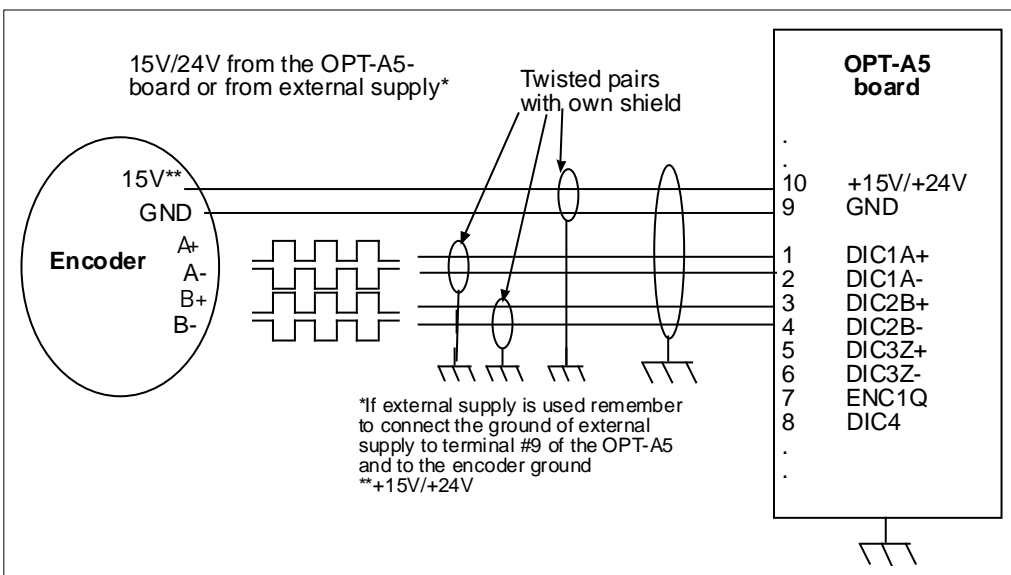

Figure 3-4. HTL type encoder connection using differential inputs

Encoder connection – Single-ended

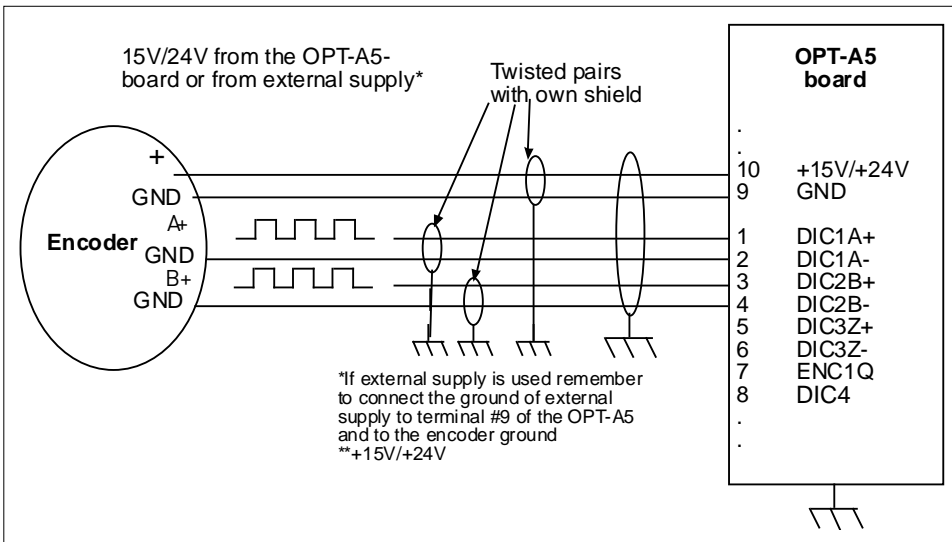

Figure 3-5. HTL type encoder connection (open source) using single-ended inputs

Note! Grounding is to be connected only at the frequency converter to avoid circulating current in the shield. Isolate shield at the encoder.

It is recommended to use double shielded cable for encoder connection.

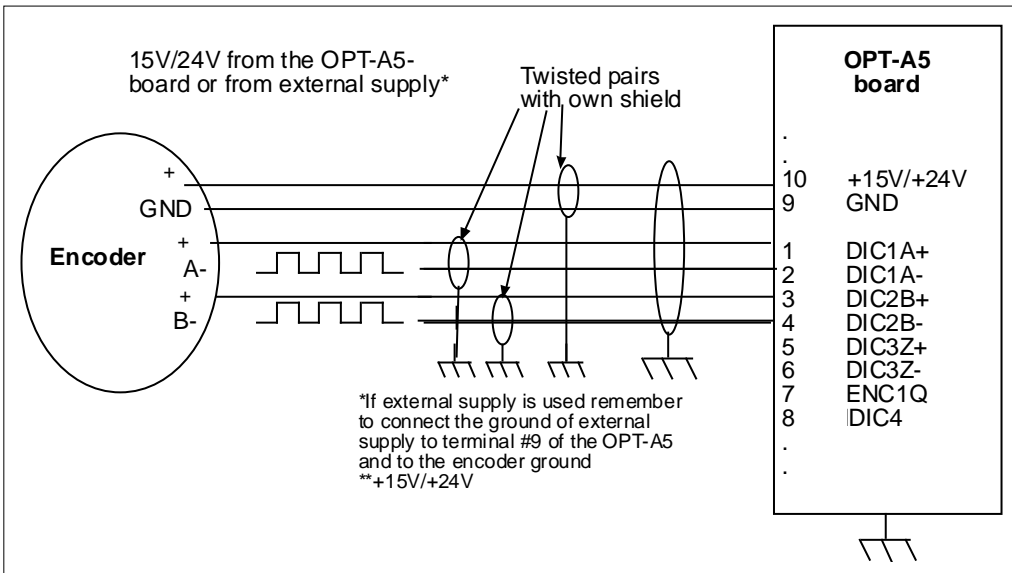

Figure 3-6. HTL type encoder connection (open collector) using single-ended inputs

Note! Grounding is to be connected only at the frequency converter to avoid circulating current in the shield. Isolate shield at the encoder.

It is recommended to use double shielded cable for encoder connection.

OPT-A5 parameters

See page 26 and 27.

3.1.6 OPT-A7

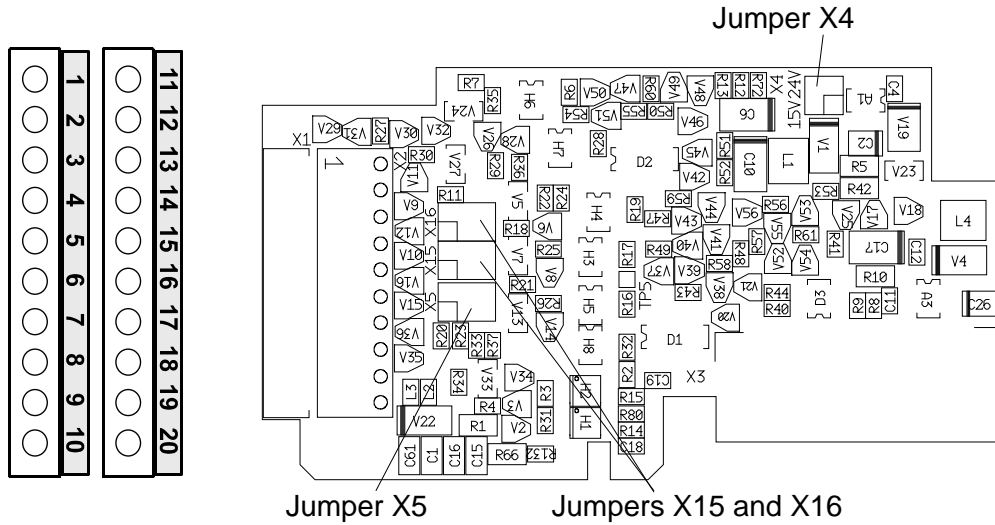

Description:

Duplicate encoder board for **Vacon NXP**. Encoder input board with programmable control voltage for the encoder.

The OPT-A7 board is designed for HTL (High voltage Transistor Logic) type encoders (voltage output type push-pull HTL, open collector output type HTL) which provide input signal levels dependent on the supply voltage of the encoder. The encoder inputs A, B and Z are galvanically isolated. The OPT-A7 board includes, too, the qualifier inputs ENC1Q and ENC2Q meant to trace positions in positioning applications.

The board can be used as both *Master* and *Slave* device. The encoder input signal is repeated on the board and carried to the next device through the digital output.

Allowed slots:

C

Type ID:

16695

Terminals:

Two terminal blocks; Screw terminals (M2.6); Coding in terminals #3 and #14.

Jumpers:

4; X4, X5, X15 and X16 (see page 34)

Board parameters:

Yes, see page 36.

I/O terminals on OPT-A7

Terminal	Parameter reference Keypad/NCDrive	Technical information
1	DIC1A+	Pulse input A (differential); Voltage range 10...24V
2	DIC1A-	
3	DIC2B+	Pulse input B; phase shift of 90 degrees compared to Pulse input A (differential); Voltage range 10...24V
4	DIC2B-	
5	DIC3Z+	Pulse input Z; one pulse per revolution (differential); Voltage range 10...24V
6	DIC3Z-	
7	ENC1Q	Qualifier input. Single-ended input with GND
8	ENC2Q	Qualifier input. Single-ended input with GND
9	GND	Ground for control and inputs ENC1Q and ENC2Q
10	+15V/+24V	Control voltage (auxiliary voltage) output to encoder; Output voltage selectable with jumper X4.
11	DID1A+	Pulse input A (differential input), voltage range 10...24V
12	DID1A-	
13	DID2B+	Pulse input B; 90 degrees phase shift compared to the pulse input A (differential input), voltage range 10...24V
14	DID2B-	
15	DID3Z+	Pulse input Z; one pulse per revolution (differential input), voltage range 10...24V
16	DID3Z-	
17	DOD1A+	Pulse output A (differential), output voltage +24V. Pulse input DIC1A or DID1A is internally repeated in the card and connected to the DOD1A output.
18	DOD1A-	
19	DOD2B+	Pulse output B (differential), output voltage +24V. Pulse input DIC2A or DID2A is internally repeated in the card and connected to the DOD2A output.
20	DOD2B-	

Table 3-9. OPT-A7 I/O terminals

Note: Encoder inputs are wide range inputs that can be used with encoders using +15V or +24V.

OPT-A7

Technical data:

Encoder control voltage, +15V/+24V	Control voltage selectable with jumper X4.
Encoder input connections, inputs A+, A-, B+, B-, Z+, Z-	Max. input frequency ≤150kHz Inputs A, B and Z are differential
Qualifier input ENC1Q	Max. input frequency ≤10kHz Min. pulse length 50µs
Fast digital input DIC1	Digital input 24V; R _i >5kΩ Digital input is single-ended; connected to GND

Note: A high pulse frequency combined with a great cable capacitance places a considerable load on the encoder. Apply therefore as low a voltage as possible for the encoder supply, rather lower than 24V. The manufacturer also recommends to place jumper X4 to position +15V, if allowed in the voltage range specification of the encoder.

Jumper selections

On the OPT-A7 board, there are four jumper blocks.

Jumper **X4** is used to program the control voltage (auxiliary voltage).

The setting of jumper **X5** defines the encoder channel (DIC/DID) used to carry the signal to the repeater.

The setting of jumpers **X15** and **X16** is changed according to whether the board is used as a *Master* or *Slave* device.

The factory default and other available jumper selections are presented below.

OPT-A7

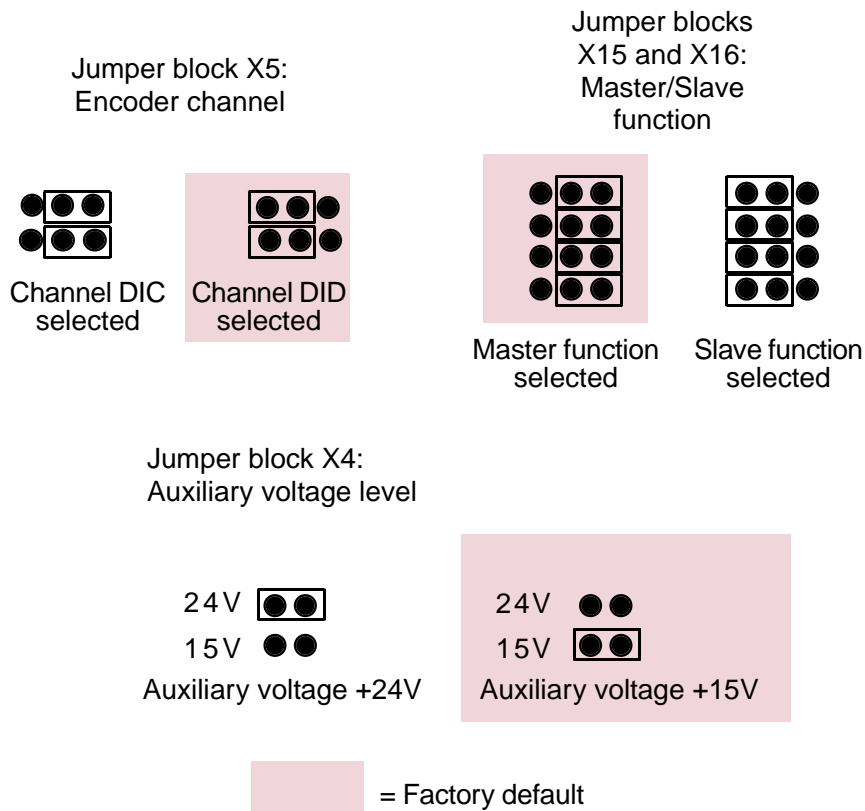

Usage: Closed Loop Vector Control, positioning applications. The OPT-A7 encoder board is mainly used in demanding system applications, e.g. when measuring the motor speed with two encoders.

Encoder connection

The figures below present examples of a chain connection of several OPT-A7 boards (Figure 3-7) and a connection of two encoders to the OPT-A7 option board (Figure 3-8).

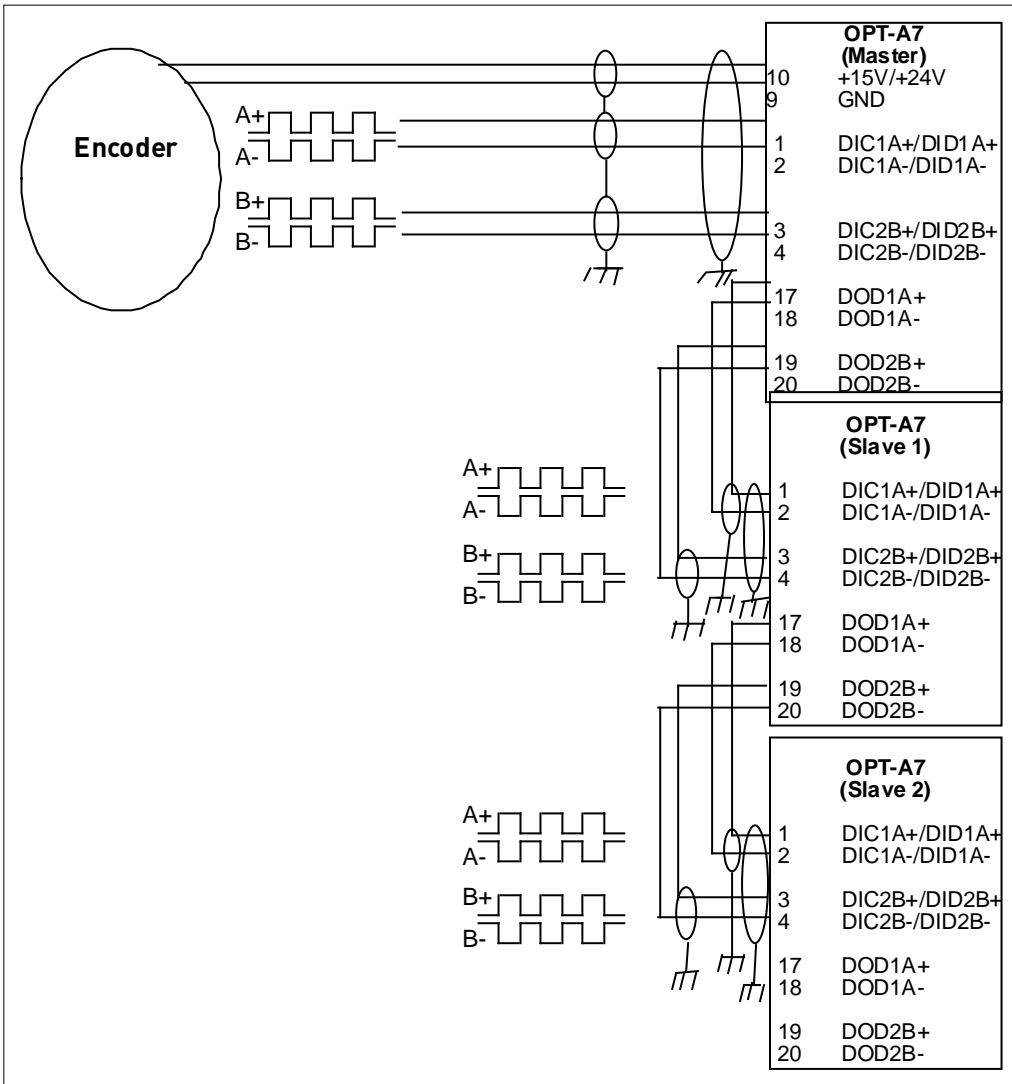

Figure 3-7. Connection of encoder and three OPT-A7 boards

OPT-A7

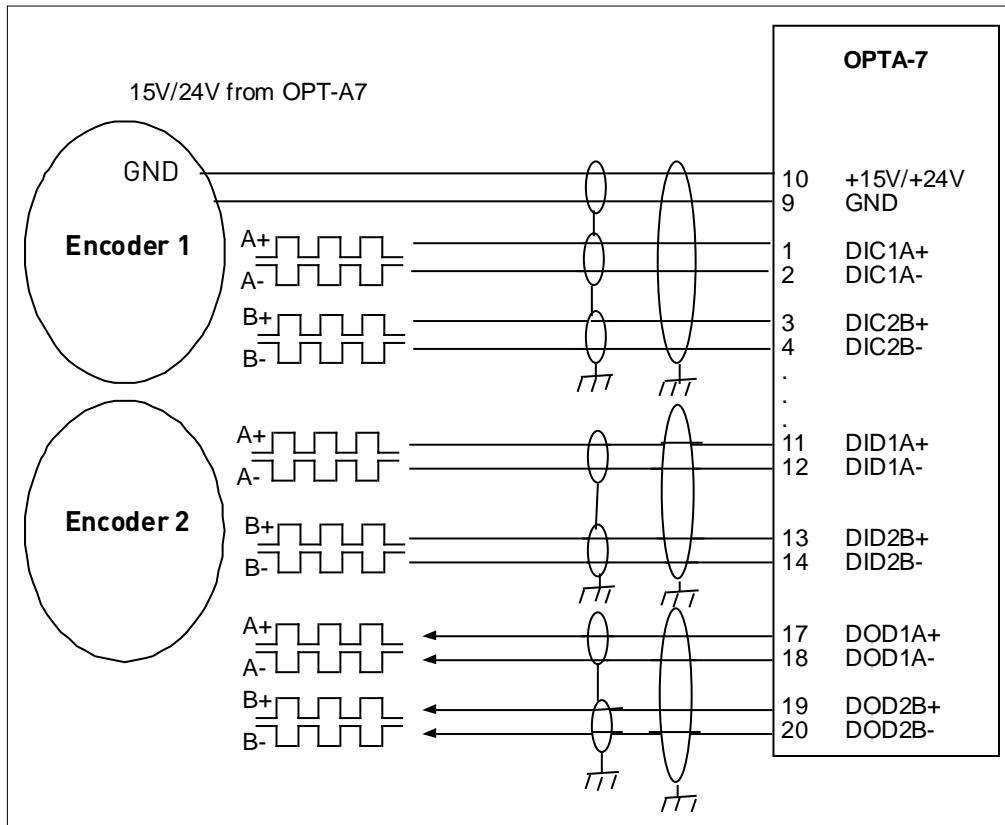

Figure 3-8. Connection of two encoders to OPT-A7 board

OPT-A7 parameters

Number	Parameter	Min	Max	Default	Note
7.3.1.1	Encoder 1 Pulse/revolution	0	65535	1024	
7.3.1.2	Invert encoder 1 direction	0	1	0	0 = No 1 = Yes
7.3.1.3	Reading rate	0	4	1	Time used to calculate speed actual value. Note: Use value 1 in Closed Loop mode. 0 = No 1 = 1 ms 2 = 5 ms 3 = 10 ms 4 = 50 ms
7.3.1.4	Encoder 2 Pulse/revolution	0	65535	1024	
7.3.1.5	Encoder 2 type	1	3	1	1 = A,B = speed 2 = A = REF, B = DIR 3 = A= FORW, B = REV See page 27 for explanations!

Table 3-10. OPT-A7 parameters

OPT-A7 monitoring values

Number	Monitored value	Unit	Description
Mon 7.3.2.1	Encoder 1 frequency	Hz	Motor speed in Hz calculated from encoder 1 pulses
Mon 7.3.2.2	Encoder 1 speed	rpm	Motor speed in rpm calculated from encoder 1 pulses
Mon 7.3.2.3	Encoder 2 frequency	Hz	Motor speed in Hz calculated from encoder 2 pulses
Mon 7.3.2.4	Encoder 2 speed	rpm	Motor speed in rpm calculated from encoder 2 pulses

Table 3-11. OPT-A7 monitoring values

3.1.7 OPT-A8

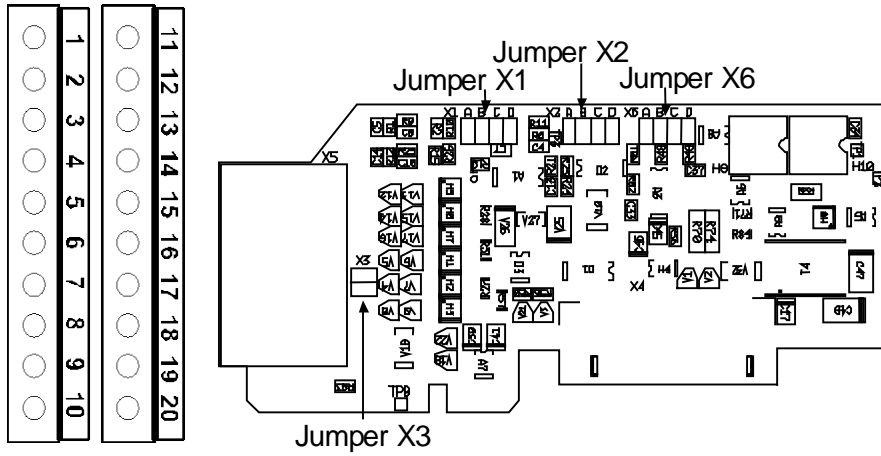

- Description:* Vacon NX basic I/O board similar to OPT-A1 except that the analogue inputs and output are **galvanically isolated**.
- Allowed slots:* A
- Type ID:* 16696
- Terminals:* Two terminal blocks; Screw terminals (M2.6); Coding in terminals #1 and #12.
- Jumpers:* 4; X1, X2, X3 and X6 (see page 40)
- Board parameters:* Yes (see page 41)

OPT-A8

I/O terminals on OPT-A8 (coded terminals painted black)

Terminal	Parameter reference Keypad/NCDrive	Technical information
1	+10 Vref	Refer.output +10V; Max.current 10mA; Decoupled from FC GND
2	AI1+	An.IN:A.1 Selection V or mA with jumper block X1 (see page 40): Default: 0- +10V (Ri = 200 kΩ) (-10V.....+10V Joy-stick control, selected with a jumper) 0- 20mA (Ri = 250 Ω) Resolution 0.1%; Accuracy ±1%
3	AI1- (GND ISOL)	GND ISOL/Voltage input; Connected to GND ISOL (selected with jumper)
4	AI2+	An.IN:A.2 Selection V or mA with jumper block X2 (see page 40): Default: 0- 20mA (Ri = 250 Ω) 0- +10V (Ri = 200 kΩ) (-10V.....+10V Joy-stick control, selected with a jumper) Resolution: 0.1%; Accuracy ±1%
5	AI2- (GND ISOL)	GND ISOL/Voltage input; Connected to GND ISOL (selected with jumper)
6	24 Vout (bidirectional)	24V auxiliary voltage output. Short-circuit protected. ±15%, maximum current 150 mA, see 1.4.4 +24Vdc external supply may be connected. Galvanically connected to terminal #12.
7	GND	Ground for reference and controls Galvanically connected to terminal #13.
8	DIN1	DigIN:A.1 Digital input 1 (Common CMA); Ri = min. 5kΩ
9	DIN2	DigIN:A.2 Digital input 2 (Common CMA); Ri = min. 5kΩ
10	DIN3	DigIN:A.3 Digital input 3 (Common CMA); Ri = min. 5kΩ
11	CMA	Digital input common A for DIN1, DIN2 and DIN3. Connection by default to GND. Selection with jumper block X3 (see page 40):
12	24 Vout (bidirectional)	Same as terminal #6 Galvanically connected to terminal #6.
13	GND	Same as terminal #7 Galvanically connected to terminals #7
14	DIN4	DigIN:A.4 Digital input 4 (Common CMB); Ri = min. 5kΩ
15	DIN5	DigIN:A.5 Digital input 5 (Common CMB); Ri = min. 5kΩ
16	DIN6	DigIN:A.6 Digital input 6 (Common CMB); Ri = min. 5kΩ
17	CMB	Digital input common A for DIN4, DIN5 and DIN6. Connection by default to GND. Selection with jumper block X3 (see page 40):
18	AO1+	AnOUT:A.1 Analogue output
19	AO1-	Output signal range: Current 0(4)-20mA, RL max 500Ω or Voltage 0-10V, RL >1kΩ Selection with jumper block X6 (see page 40): Resolution: 0.1% (10 bits); Accuracy ±2%;
20	DO1	DigOUT:A.1 Open collector output; Max. Uin = 48VDC; Max. current = 50 mA

OPT-A8

Table 3-12. OPT-A8 I/O terminals

Jumper selections

There are four jumper blocks on the OPT-A8 board. The factory defaults and other available jumper selections are presented below.

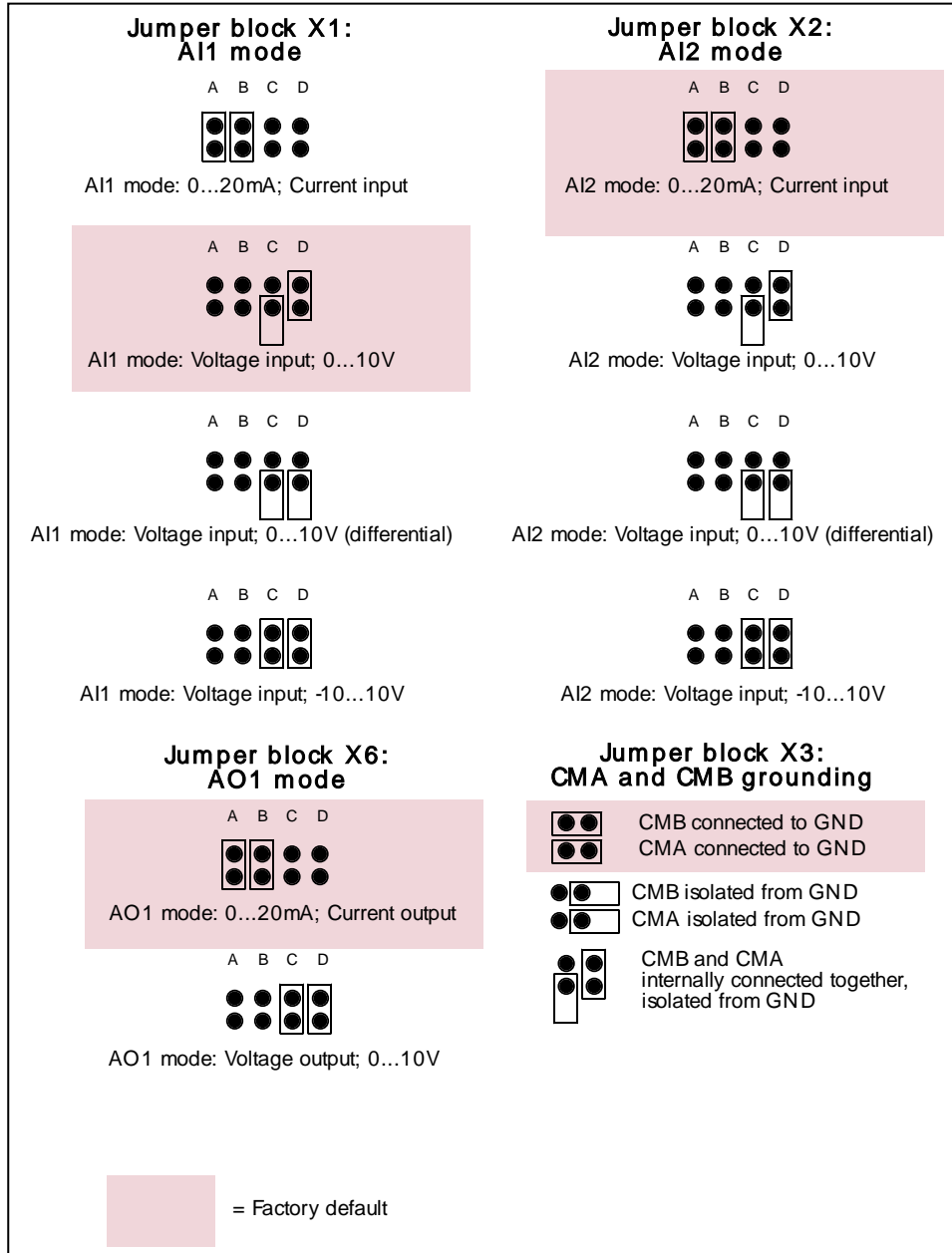

Table 3-13. Jumper positions for OPT-A8

OPT-A8 parameters

Number	Parameter	Min	Max	Default	Note
1	AI1 mode	1	5	3	1 = 0...20mA 2 = 4...20mA 3 = 0...10V 4 = 2...10V 5 = -10...+10V
2	AI2 mode	1	5	1	1 = 0...20mA 2 = 4...20mA 3 = 0...10V 4 = 2...10V 5 = -10...+10V
3	AO1 mode	1	4	1	1 = 0...20mA 2 = 4...20mA 3 = 0...10V 4 = 2...10V

Table 3-14. OPT-A8 board-related parameters

3.1.8 OPT-A9

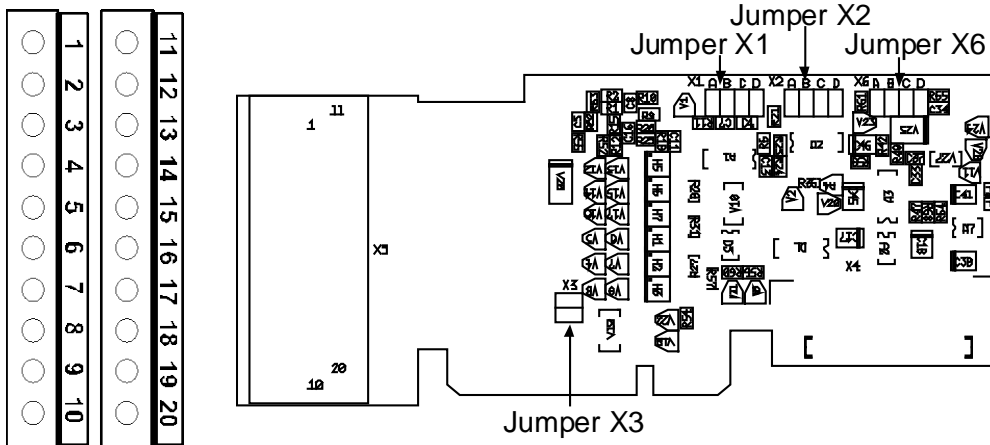

- Description:* Vacon NX basic I/O board similar to the OPT-A1 except that the I/O terminals are bigger (for 2.5mm² wires; M3 screws).
- Allowed slots:* A
- Type ID:* 16697
- Terminals:* Two terminal blocks; Screw terminals (M3); Coding in terminals #1 and #12.
- Jumpers:* 4; X1, X2, X3 and X6 (see page 20)
- Board parameters:* Yes (see page 21)

I/O terminals on OPT-A9

See page 19.

Jumper selections

See page 20.

OPT-A9 parameters

See page 21.

NXOPT-A9

3.1.9 OPT-AL

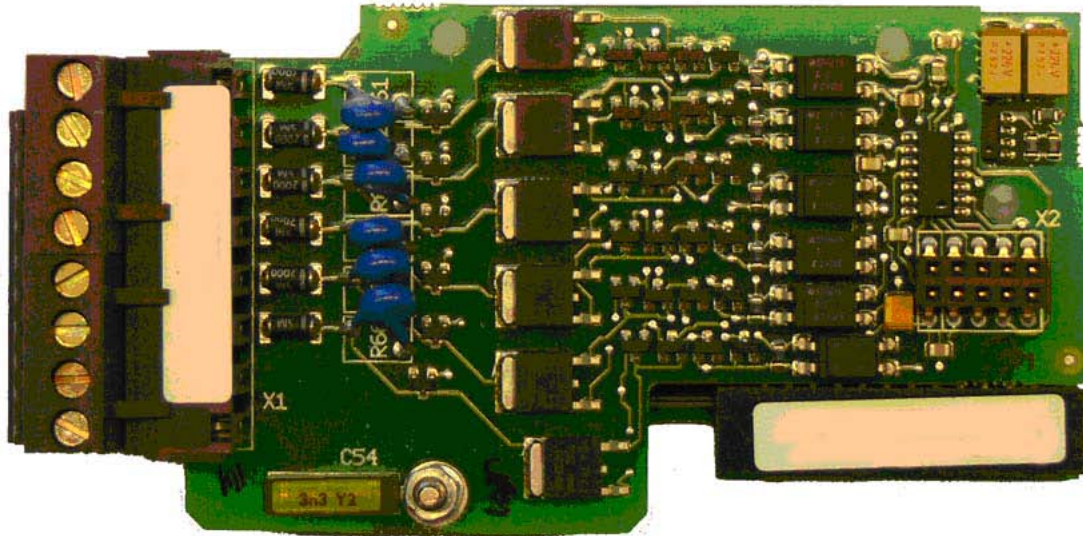

- Description:* Dual I/O expander board with six 42...240 VAC digital inputs, 2 analog inputs, two analog outputs, one digital output and 15 and 24 V out.
- Allowed slots:* A
- Type ID:* 16716
- Terminals:* Two terminal blocks; Screw terminals (M2.6, 1,5 mm² wire terminals 1 – 10; M3, 2,5 mm² wire terminals 11-18); No coding
- Jumpers:* None
- Board parameters:* None

I/O terminals on OPT-AL

Terminal		Parameter reference Keypad/NCDrive	Technical information
1	+15 V		15 V out – together with terminal 2 max 200 mA
2	+15 V		15 V out
3	AI1	An.IN:A.1	Analog input 0 – 10 V
4	AI2	An.IN:A.2	Analog input ± 10 V
5	GND		Ground for analog signals
6	A01+	AnOUT:A.1	Analog output 0 (4) – 20 mA
7	A02+	AnOUT:A.2	Analog output 0 – 10 V
8	D01		Open collector digital output , 48 V, 50 mA allowed
9	GND		Ground for analog signals
10	+ 24 V		24 V out – max 200 mA

11	ACIN1	DigIN:X.1	Digital input, 42...240 VAC (threshold 35V) Control voltage: "0"<33V, "1">35V
12	ACIN2	DigIN:X.2	Digital input, 42...240 VAC (threshold 35V) Control voltage: "0"<33V, "1">35V
13	ACIN3	DigIN:X.3	Digital input, 42...240 VAC (threshold 35V) Control voltage: "0"<33V, "1">35V
14	ACIN4	DigIN:X.4	Digital input, 42...240 VAC (threshold 35V) Control voltage: "0"<33V, "1">35V
15	ACIN5	DigIN:X.5	Digital input, 42...240 VAC (threshold 35V) Control voltage: "0"<33V, "1">35V
16	ACIN6	DigIN:X.6	Digital input, 42...240 VAC (threshold 35V) Control voltage: "0"<33V, "1">35V
17 18	COMMON		Common input for DI1 - 6

Table 3-15. OPT-AL I/O terminals

3.1.10 OPT-AE

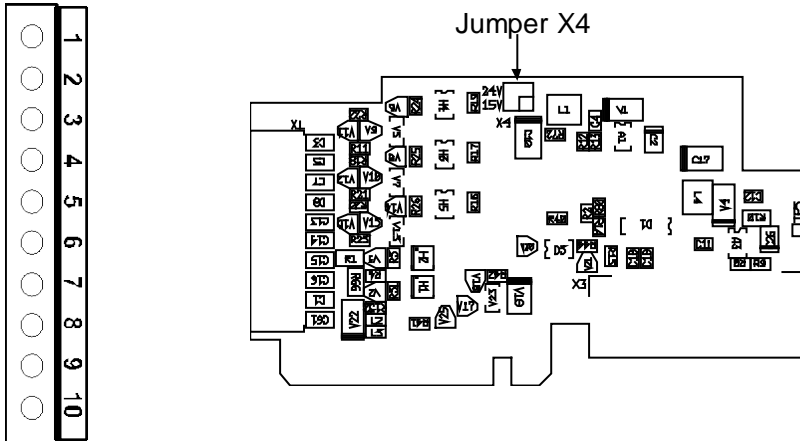

Description:

Encoder board for **Vacon NXP**. Encoder input board with programmable control voltage for an encoder.

The OPT-AE board is designed for HTL (High voltage Transistor Logic) type encoders (voltage output type push-pull HTL, open collector output type HTL) which provide input signal levels dependent on the supply voltage of the encoder. The encoder inputs A, B and Z are galvanically isolated. In addition, the board includes an Encoder Direction Signal and an Encoder Pulse Output Signal. The Encoder Direction Signal value '1' indicates a backward motor direction and '0' a forward motor direction. The Encoder Pulse Output signal is produced from The Encoder input signals (channel A) divided by the divider parameter (see page 48).

Allowed slots:

C

Type ID:

16709

Terminals:

One terminal block; Screw terminals (M2.6); Coding in terminal #3.

Jumpers:

1; X4 (see page 46)

Board parameters:

Yes

OPT-AE

I/O terminals on OPT-AE (coded terminal painted black)

Terminal		Parameter reference Keypad/NCDrive	Technical information
1	DIC1A+		Pulse input A (differential); Voltage range 10...24V
2	DIC1A-		
3	DIC2B+		Pulse input B; phase shift of 90 degrees compared to Pulse input A (differential); Voltage range 10...24V
4	DIC2B-		
5	DIC3Z+		Pulse input Z; one pulse per revolution (differential); Voltage range 10...24V
6	DIC3Z-		
7	D01		Encoder divider output. Encoder input signals are divided by divider parameter (see parameter list on page 48)
8	D02		Encoder direction output. The signal value '1' means that the motor direction is backward and '0' is forward.
9	GND		Ground for control
10	+15V/+24V		Control voltage (auxiliary voltage) output to encoder; Output voltage selectable with jumper X4.

Table 3-16. OPT-AE I/O terminals

Note: Encoder inputs are wide range inputs that can be used with encoders using +15V or +24V

Technical data:

Encoder control voltage, +15V/+24V	Control voltage selectable with jumper X4.
Encoder input connections, inputs A+, A-, B+, B-, Z+, Z-	Max. input frequency ≤150kHz Inputs A, B and Z are differential
Encoder divider output D01, Encoder direction output D02	Max. load voltage 60Vdc Max. load current 50mA Max. output frequency ≤300kHz

Jumper selections

On the OPT-AE board, there is one jumper block used to program the control voltage (auxiliary voltage). The factory default and other available jumper selections are presented below.

**Jumper block X4:
Auxiliary voltage level**

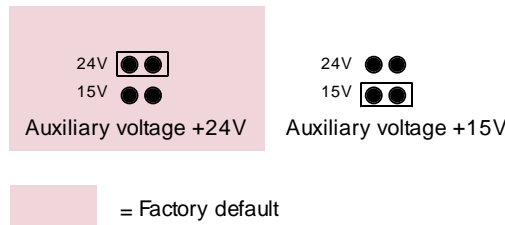

Usage: Closed Loop Vector Control. The OPT-AE board is mainly used in conventional industrial applications where encoder cable lengths are relatively long.

Encoder connection - single-ended

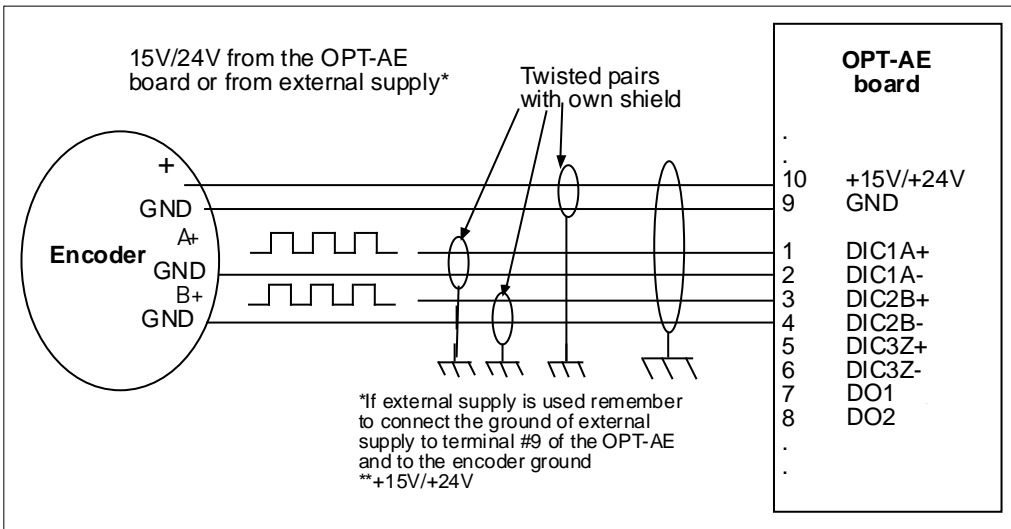

Figure 3-9. HTL type encoder connection (open source) using single-ended inputs

Note! Grounding is to be connected only at the frequency converter to avoid circulating current in the shield. Isolate shield at the encoder.

It is recommended to use double shielded cable for encoder connection.

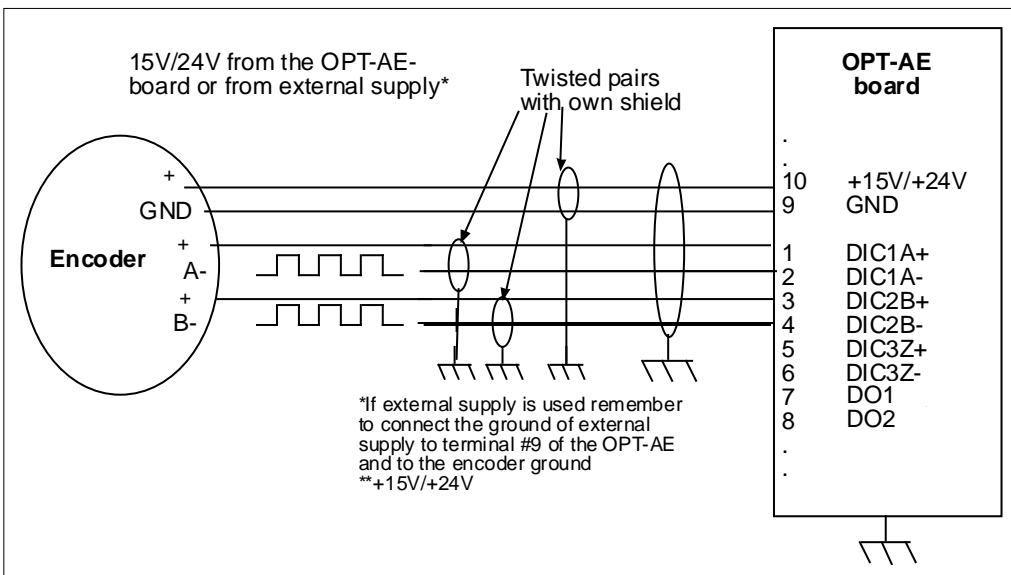

Figure 3-10. HTL type encoder connection (open collector) using single-ended inputs

Note! Grounding is to be connected only at the frequency converter to avoid circulating current in the shield. Isolate shield at the encoder.

It is recommended to use double shielded cable for encoder connection.

Encoder connection – differential

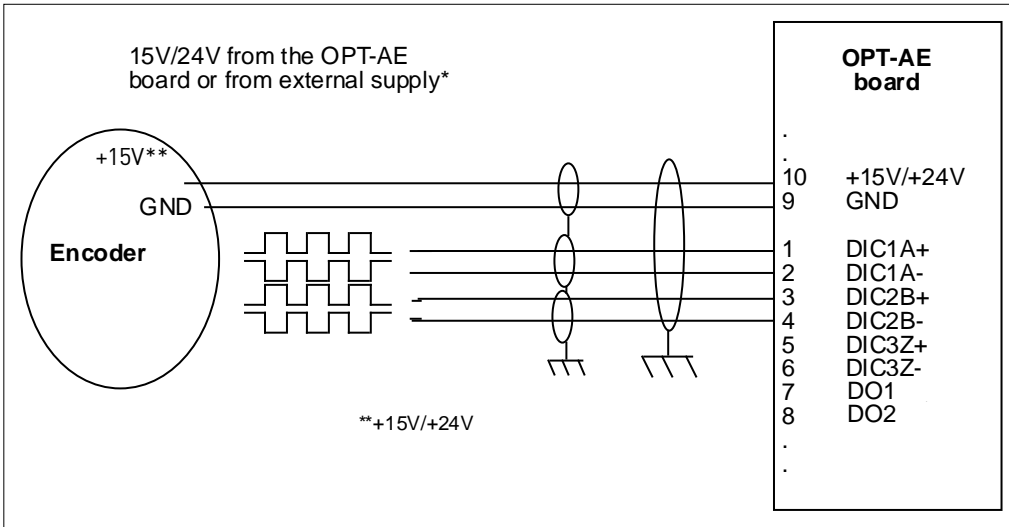

Figure 3-11. HTL type encoder connection using differential inputs

OPT-AE parameters

Number	Parameter	Min	Max	Default	Note
7.3.1.1	Pulse/revolution	1	65535	1024	
7.3.1.2	Invert direction	0	1	0	0 = No 1 = Yes
7.3.1.3	Reading rate	0	4	1	Time used to calculate speed actual value. Note: Use value 1 in Closed Loop mode. 0 = No calculation 1 = 1 ms 2 = 5 ms 3 = 10 ms 4 = 50 ms
7.3.1.4	Divider Value	1	2048	64	Input pulses / Divider = Divider Output
7.3.1.5	Hysteresis for Direction Out	0	511	8	Number of pulses before direction signal change state

Table 3-17. OPT-AE board-related parameters

3.1.11 OPT-AN

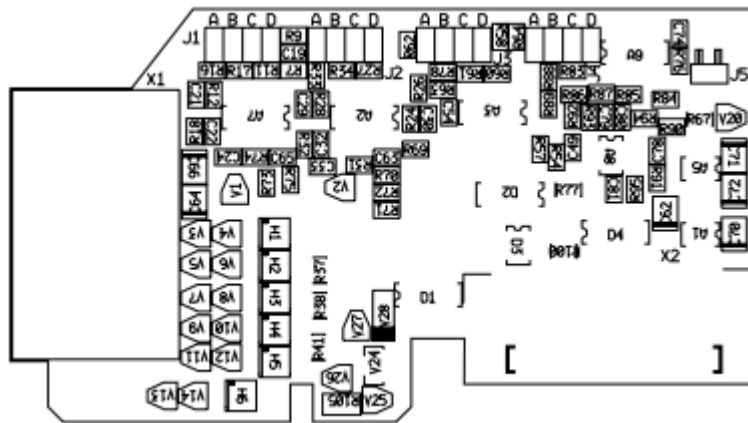

Description: Standard I/O board for **Vacon NXP** with 6 galvanically isolated digital inputs and two analogue inputs/outputs. The Analogue channels are programmable:

- 1 = 0...20mA
- 2 = 4...20mA
- 3 = 0...10V
- 4 = 2...10V
- 5 = -10...+10V

Allowed slots: **A**

Type ID: 16718

Terminals: Two terminal blocks (coded = mounting of blocks in wrong order prevented, terminals #1 and #12);

Screw terminals (M2.6)

Jumpers: J1, J2, J3, J4

Board parameters: Yes (see page 51)

I/O terminals on OPT-AN

Terminal		Technical information
1	AI1-	Selection V or mA with jumper block J1 Default: 0- +10V (Ri = 200 kΩ)
2	AI1+	(-10V..+10V Joy-stick control, selected with jumper) 0- 20mA (Ri = 250 Ω) Resolution 0.1%; Accuracy ±1% Differential input if not connected to ground; Allows ±20V differential mode voltage to GND
3	AI2-	Selection V or mA with jumper block J2 Default: 0- +10V (Ri = 200 kΩ)
4	AI2+	(-10V..+10V Joy-stick control, selected with jumper) 0- 20mA (Ri = 250 Ω) Resolution 0.1%; Accuracy ±1% Differential input if not connected to ground; Allows ±20V differential mode voltage to GND
5	-10V_POT_REF	10V reference voltage 10mA
6	GND POT COM	Common for POT
7	+10V_POT_REF	+10V reference voltage 10mA
8	AO1+	Analogue output
9	GND AO COM	Output signal range: Current 0(4)–20mA, RL max 500Ω, Voltage 0—10V, RL >1kΩor Voltage -10-+10, RL>1kΩ
10	AO2+	Selection V or mA with jumper blocks J3 for AO1, J4 for AO2 Resolution: 0.1% (10 bits); Accuracy ±2%
11	DIN1	Digital input 1 (Common DI COM); Ri = min. 5kΩ
12	DIN2	Digital input 2 (Common DI COM); Ri = min. 5kΩ
13	DIN3	Digital input 3 (Common DI COM); Ri = min. 5kΩ
14	DIN4	Digital input 4 (Common DI COM); Ri = min. 5kΩ
15	DIN5	Digital input 5 (Common DI COM); Ri = min. 5kΩ
16	DIN6	Digital input 6 (Common DI COM); Ri = min. 5kΩ
17	DI COM	DI COM isolated from GND
18	DI COM	DI COM isolated from GND
19	24 V out (bi-directional)	24V auxiliary voltage output. Short-circuit protected. ±15%, maximum current 150 mA, +24Vdc external supply may be connected.
20	GND 24V COM	Ground for reference and controls

Table 3-18. OPT-AN I/O terminals

Jumper selections

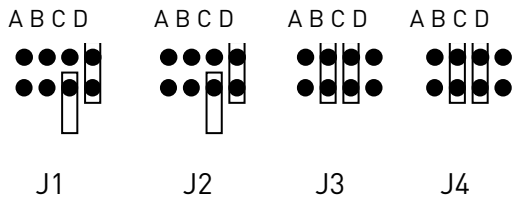

J1 (AI1), J2 (AI2)	Analog Input Mode	0 ... 10	D (default)
J1 (AI1), J2 (AI2)	Analog Input Mode	-10 ... +10V	CD
J1 (AI1), J2 (AI2)	Analog Input Mode	0 ... 20mA	AB
J3 (AO1), J4 (AO2)	Analog Output	0 ... 10V	BC (default)
J3 (AO1), J4 (AO2)	Analog Output	-10 ... +10V	CD
J3 (AO1), J4 (AO2)	Analog Output	0 ... 20mA	AB

OPT-AN board parameters

Number	Parameter	Min	Max	Default	Note
7.1.1.1	AI1 mode	1	5	3	1 = 0...20mA 2 = 4...20mA 3 = 0...10V 4 = 2...10V 5 = -10...+10V
7.1.1.2	AI2 mode	1	5	3	1 = 0...20mA 2 = 4...20mA 3 = 0...10V 4 = 2...10V 5 = -10...+10V
7.1.1.3	AO1 mode	1	5	3	1 = 0...20mA 2 = 4...20mA 3 = 0...10V 4 = 2...10V 5 = -10...+10V
7.1.1.4	AO2 mode	1	5	3	1 = 0...20mA 2 = 4...20mA 3 = 0...10V 4 = 2...10V 5 = -10...+10V

Table 3-19. OPT-AN board-related parameters

OPT-AN

OPT-AN board I/O monitor values

Number	Parameter	Description
7.1.2.1	DigIN:A.1	DIN1 Status
7.1.2.2	DigIN:A.2	DIN2 Status
7.1.2.3	DigIN:A.3	DIN3 Status
7.1.2.4	DigIN:A.4	DIN4 Status
7.1.2.5	DigIN:A.5	DIN5 Status
7.1.2.6	DigIN:A.6	DIN6 Status
7.1.2.7	DigIN:A.8	Not in use
7.1.2.8	DigOUT:A.1	Not in use
7.1.2.9	AnIN:A.1	AI1 Status
7.1.2.10	AnIN:A.2	AI2 Status
7.1.2.11	AnOUT:A.1	AO1 Status
7.1.2.12	AnOUT:A.2	AO2 Status

Table 3-20. OPT-AN board monitor values

3.2 I/O Expander Boards OPT-B_

- Option boards used for I/O expansion
- This board type can normally be plugged into slots **B, C, D** or **E**.

The number of control inputs and outputs on your Vacon frequency converter can be increased with the *I/O Expander boards*. This kind of boards can usually be placed in any board slot inside the frequency converter control unit except for slot A.

There are no board-related parameters for OPT-B_ I/O expander boards (except for board OPT-BB).

The boards you wish to have installed in your frequency converter have to be defined in the type designation code of the frequency converter when ordering it from the factory.

FC type	I/O board	Allowed slots	DI	AI	TI	AO	DO	RO	Pt-100	42-240 VAC input	Other
NXS NXP	OPT-B1	B,C,D,E	(6)				(6)				
NXS NXP NXL	OPT-B2	B,C,D,E			1			2			
NXS NXP NXL	OPT-B4	B,C,D,E		1 (isolated); (mA)		2 (isolated mA)					+24V/ EXT+24V
NXS NXP NXL	OPT-B5	B,C,D,E						3			
NXS NXP	OPT-B8	B,C,D,E							3		
NXS NXP	OPT-B9	B,C,D,E						1		5	
NXS NXP	OPT-BB	C	2 (enc)								

Table 3-21. Vacon NX I/O Expander boards and their equipment

DI = Digital input
 AI = Analogue input
 TI = Thermistor input

Pt-100 = Sensor input for Pt-100
 AO = Analogue output
 RO = Relay output

3.2.1 OPT-B1

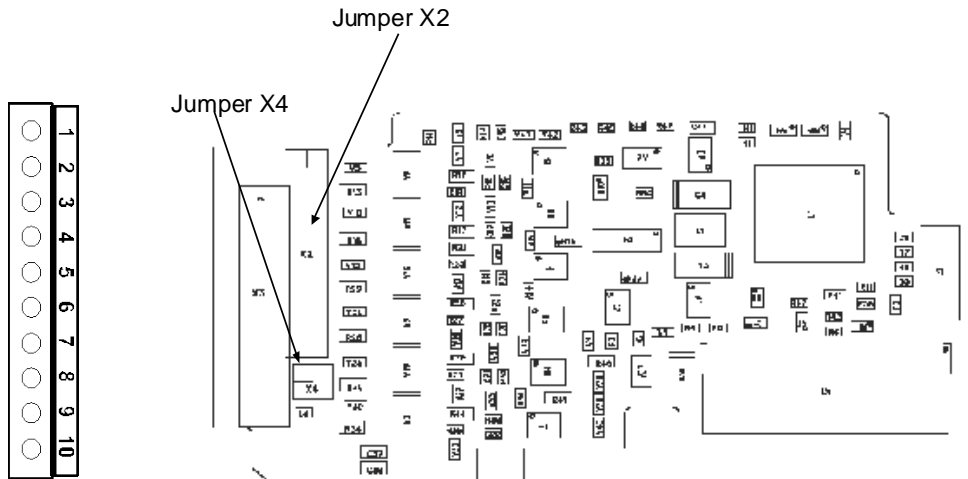

Description: Vacon NX I/O expander board with six bidirectional terminals.

Allowed slots: B, C, D, E

Type ID: 16945

Terminals: One terminal block; Screw terminals (M2.6); No coding

Jumpers: 2; X2 and X4 (see page 55)

Board parameters: None

I/O terminals on OPT-B1

Terminal		Parameter reference Keypad/NCDriver	Technical information
1	DIO1	DigIN: X.1 DigOUT: X.1	<u>Digital input:</u> 24V; R _i >5kΩ <u>Digital output:</u> Open collector, 50mA/48V
2	DIO2	DigIN: X.2 DigOUT: X.2	See above.
3	DIO3	DigIN: X.3 DigOUT: X.3	See above.
4	CMA		Common for DIO1...DIO3. Note: CMA is internally connected to GND with jumper by default.
5	DIO4	DigIN: X.4 DigOUT: X.4	<u>Digital input:</u> 24V; R _i >5kΩ <u>Digital output:</u> Open collector, 50mA/48V
6	DIO5	DigIN: X.5 DigOUT: X.5	See above.
7	DIO6	DigIN: X.6 DigOUT: X.6	See above.
8	CMB		Common for DIO4...DIO6
9	GND		I/O ground; Ground for reference and controls.
10	+24V		Control voltage output; Voltage for switches etc.; max. current 150mA; Short-circuit protected.

Table 3-22. OPT-B1 I/O terminals

Jumper selections

On the OPT-B1 board, there are two jumper blocks. The jumper block X2 is used to define the bidirectional terminal as either input or output. The other jumper block, X4, is used to connect the common terminals to GND. The factory default and other available jumper selections are presented below.

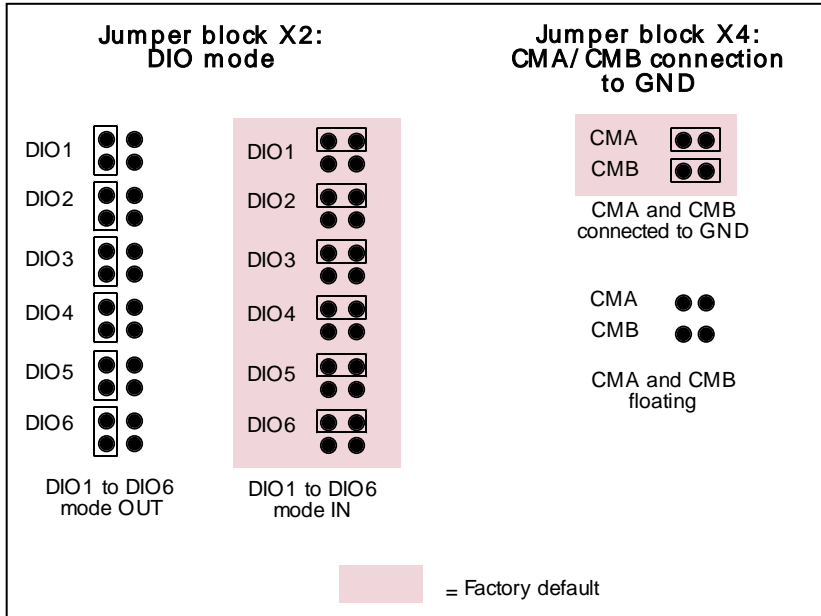
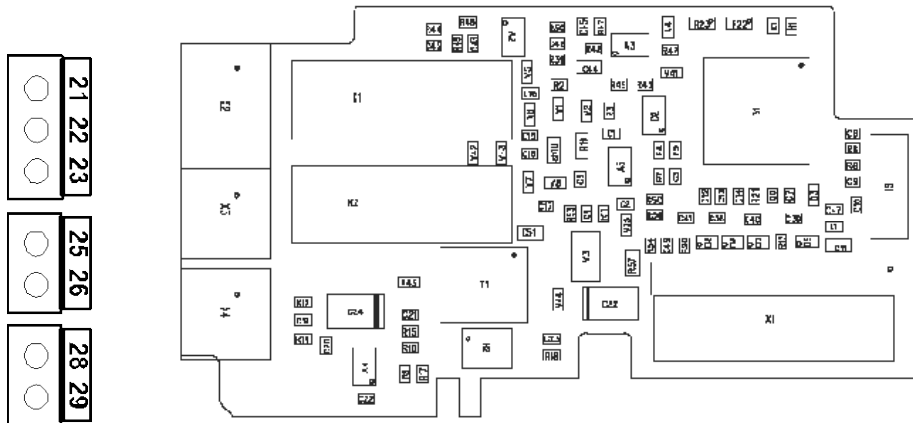

Figure 3-12. Jumper positions for OPT-B1

3.2.2 OPT-B2



- Description:* Vacon NX I/O expander board with a thermistor input and two relay outputs.
- Allowed slots:* B, C, D, E
- Type ID:* 16946
- Terminals:* Three terminal blocks; Screw terminals (M3); No coding
- Jumpers:* None
- Board parameters:* None

I/O terminals on OPT-B2

Terminal		Parameter reference Keypad/NCDrive	Technical information	
21	R01/normal closed	DigOUT:X.1	Switching capacity	24VDC/8A
22	R01/common			250VAC/8A
23	R01/normal open			125VDC/0.4A
			Min. switching load	5V/10mA
25	R02/common	DigOUT:X.2	Switching capacity	24VDC/8A
26	R02/normal open			250VAC/8A
				125VDC/0.4A
			Min. switching load	5V/10mA
28	T11+	DigIN:X.1	Thermistor input (galvanically isolated)	
29	T11-		R _{trio} = 4.7kΩ	

Table 3-23. OPT-B2 I/O terminals

Note: This expander board can be placed into four different slots on the control board. Therefore, the 'X' given in the Parameter reference shall be replaced by the slot letter (B, C, D, or E) depending on the slot which the expander board is plugged into. See Chapter 1.7

3.2.3 OPT-B4

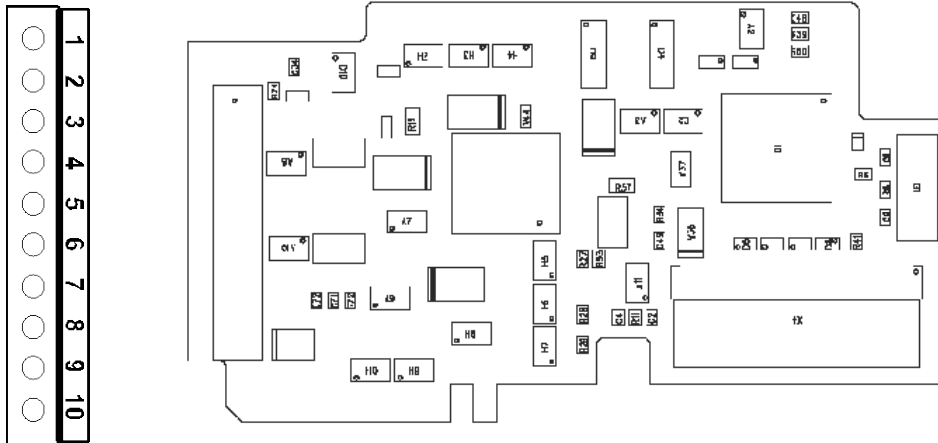

- Description:** Vacon NX I/O expander board with one galvanically isolated analogue input and two galvanically isolated analogue outputs (standard signals 0(4)...20mA).
- Allowed slots:** B, C, D, E
- Type ID:** 16948
- Terminals:** One terminal block; Screw terminals (M2.6); No coding
- Jumpers:** None
- Board parameters:** None

I/O terminals on OPT-B4

Terminal	Parameter reference Keypad/NCDrive	Technical information
1	A11+	0(4)...20mA; $R_i=250\Omega$; galvanically isolated Resolution 10 bits/0.1%; Accuracy $\pm 1\%$ of the full display
2	A11-	
3	A01+	0(4)...20mA; $R_L<500\Omega$; Resolution 10 bits/0.1%; Accuracy $\leq \pm 2\%$ (galvanically isolated)
4	A01-	
5	A02+	0(4)...20mA; $R_L<500\Omega$; Resolution 10 bits/0.1%; Accuracy $\leq \pm 2\%$ (galvanically isolated)
6	A02-	
7	GND	24V ($\pm 15\%$); Max. load 250mA (total load from EXT+24V outputs), max. 150mA from one board. See <i>Figure 1-3</i> on page 8. 24V ($\pm 15\%$), in special applications where PLC type functions are included in the control module, this input can be used as external auxiliary power supply for control boards as well as for I/O boards.
8	GND	
9	GND	
10	+24V	

Table 3-24. OPT-B4 I/O terminals

Note: This expander board can be placed into four different slots on the control board. Therefore, the 'X' given in the Parameter reference shall be replaced by the slot letter (B, C, D, or E) depending on the slot which the expander board is plugged into. See Chapter 1.7.

OPT-B4

3.2.4 OPT-B5

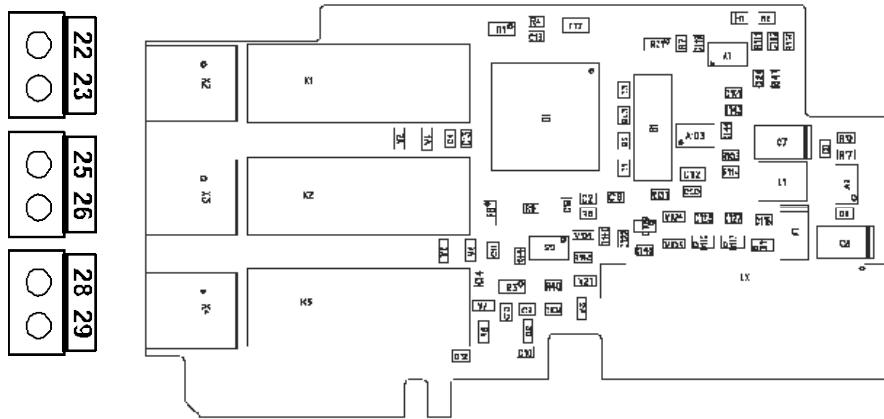

- Description:* I/O expander board with three relay outputs.
- Allowed slots:* B, C, D, E
- Type ID:* 16949
- Terminals:* Three terminal blocks; Screw terminals (M3); No coding
- Jumpers:* None
- Board parameters:* None

I/O terminals on OPT-B5

Terminal		Parameter reference Keypad/NCDrive	Technical information	
22	R01/common	DigOUT:X.1	Switching capacity	24VDC/8A
23	R01/normal open			250VAC/8A
			Min. switching load	125VDC/0.4A
				5V/10mA
25	R02/common	DigOUT:X.2	Switching capacity	24VDC/8A
26	R02/normal open			250VAC/8A
			Min. switching load	125VDC/0.4A
				5V/10mA
28	R03/common	DigOUT:X.3	Switching capacity	24VDC/8A
29	R03/normal open			250VAC/8A
			Min. switching load	125VDC/0.4A
				5V/10mA

Table 3-25. OPT-B5 I/O terminals

Note: This expander board can be placed into four different slots on the control board. Therefore, the 'X' given in the Parameter reference shall be replaced by the slot letter (B, C, D, or E) depending on the slot which the expander board is plugged into. See chapter 1.7.

3.2.5 OPT-B8

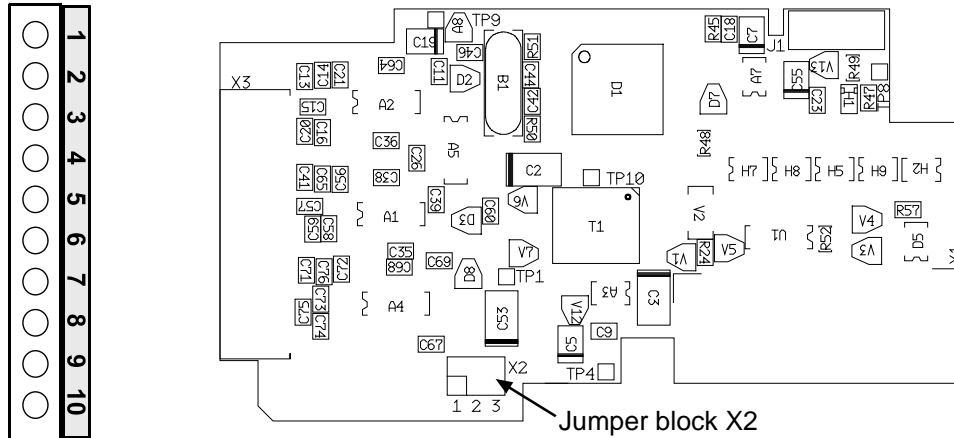

Description: Temperature measuring board with three Pt-100 sensor (3-wire) inputs. The measurable temperature range is -30...200 C° on Pt-100 input. Both 3-wire and 2-wire elements can be used.

Allowed slots: B, C, D, E

Type ID: 16952

Terminals: One terminal block; Screw terminals (M2.6); No coding

Jumpers: X2

Board parameters: None

I/O terminals on OPT-B8

Terminal	Parameter reference Keypad/NCDrive	Technical information
1	R1 +	AnIN:X.1 PT100 Input, -30 ... 200 °C, one sensor. Accuracy ≤ 1°C. Sensor current 10 mA.
2	R _m 1	
3	R1 -	
4	R2 +	AnIN:X.2 PT100 Input, -30 ... 200 °C, one sensor. Accuracy ≤ 1°C. Sensor current 10 mA.
5	R _m 2	
6	R2-	
7	R3 +	AnIN:X.3 PT100 Input, -30 ... 200 °C 1 - 3 sensors (see X2 jumper selections). Accuracy ≤ 1°C. Sensor current 10 mA.
8	R _m 3	
9	R3 -	
10	NC	Not connected

Table 3-26. OPT-B8 I/O terminals

OPT-B8

Connection of PT100 sensors

One PT100-sensor can be connected to the first two inputs (terminals 1 to 3 and 4 to 6) and up to three sensors to the third input (terminals 7 to 9). The sensors must be connected in **series** with a two- or three-wire connection. See Chapter Jumper selections below.

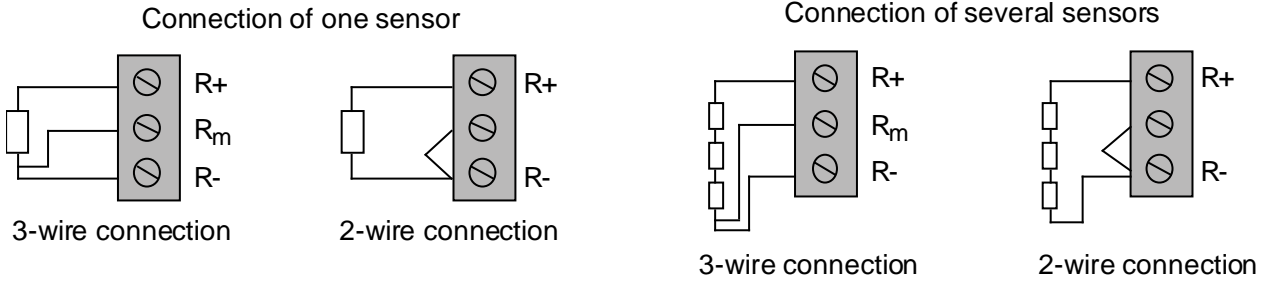

Note:

- This expander board can be placed into four different slots on the control board. Therefore, the 'X' given in the Parameter reference shall be replaced by the slot letter (B, C, D, or E) depending on the slot which the expander board is plugged into. See chapter 1.7.
- Insulation level 4kV/sqrt(2) (DIN VDE 01 10-1). 2kV in sensor and 2kV in option board.

Jumper selections

Up to three PT100 sensors can be connected to the third PT100 input. You can select the number of sensors in use with jumper block X2:

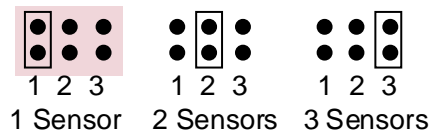

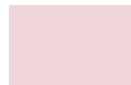
 = Factory default

3.2.6 OPT-B9

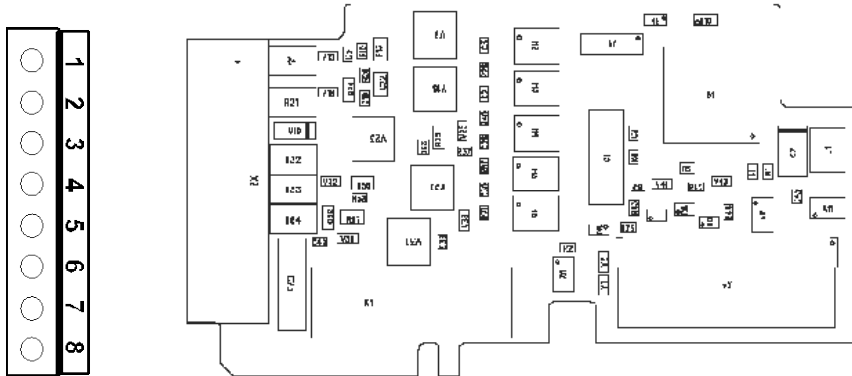

- Description:** I/O expander board with five 42...240 VAC digital inputs and one normal relay output.
- Allowed slots:** B, C, D, E
- Type ID:** 16953
- Terminals:** One terminal block; Screw terminals (M2.6); No coding
- Jumpers:** None
- Board parameters:** None

I/O terminals on OPT-B9

Terminal	Parameter reference Keypad/NCDrive	Technical information
1	ACIN1	DigIN:X.1 Digital input, 42...240 VAC (threshold 35V) Control voltage: "0"<33V, "1">35V
2	ACIN2	DigIN:X.2 Digital input, 42...240 VAC (threshold 35V) Control voltage: "0"<33V, "1">35V
3	ACIN3	DigIN:X.3 Digital input, 42...240 VAC (threshold 35V) Control voltage: "0"<33V, "1">35V
4	ACIN4	DigIN:X.4 Digital input, 42...240 VAC (threshold 35V) Control voltage: "0"<33V, "1">35V
5	ACIN5	DigIN:X.5 Digital input, 42...240 VAC (threshold 35V) Control voltage: "0"<33V, "1">35V
6	COMA	Digital input, 42...240 VAC (threshold 35V) Control voltage: "0"<33V, "1">35V
7	R01/common	DigOUT:X.1 Switching capacity 24VDC/8A 250VAC/8A 125VDC/0.4A
8	R01/normal open	

Table 3-27. OPT-B9 I/O terminals

Note: This expander board can be placed into four different slots on the control board. Therefore, the 'X' given in the Parameter reference shall be replaced by the slot letter (B, C, D, or E) depending on the slot which the expander board is plugged into. See chapter 1.7.

3.2.7 OPT-BB

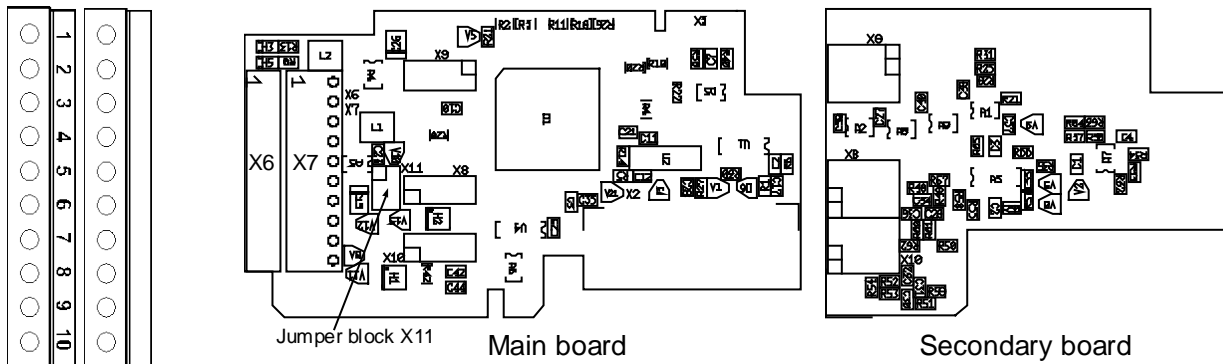

Description: Absolute encoder board for **Vacon NXP** with inputs for an *Endat* type encoder. Programmable control voltage, fast digital inputs and simulation pulse output. The output pulse is produced from sinusoidal input signals.

The galvanically isolated fast digital inputs are used to trace very short pulses.

Allowed slots: C

Type ID: 16962 (main board), 16963 (secondary board); The secondary board is mounted on top of the main board

Terminals: Two terminal blocks; Screw terminals (M2.6); No coding

Jumpers: 1; X11 (see page 57)

Board parameters: Yes (see page 64)

An **absolute encoder** is a type of encoder capable of specifying its absolute position. The position data is retained even during a power failure or breakdown. The position data carried by the absolute encoder can be used by the frequency converter motor control in the control of a synchronous motor.

Encoder cable	Heidenhain cable; Max. length 100m
Encoder voltage	5V, 12V or 15V Max. current consumption 300mA
Measuring steps/ revolution	4,2 billion (max. 32bit)
Distiguishable revolutions	0—65535 (max. 16bit)
Signal periods/revolution	1—65535

ENDAT is a bidirectional synchronic serial interface for absolute encoders. For example, the encoder position data can be read and encoder parameters can be set via the ENDAT connection. It also forwards the messages related to the encoder functions.

All Endat connections are available in terminal X6. The board uses Endat version 2.

Sinus signals require some precautions for noise immunity that may be a little more demanding than conventional square wave encoders. Use of twisted pairs (possibly with individual shielding of each pair) is recommended. Use one pair for sinus+ and sinus-, another pair for cosinus+ and cosinus-, another pair for data+ data- of the absolute serial channel, another pair for clock+ and clock- of absolute channel.

I/O terminals on OPT-BB, encoder terminal X6

Terminal		Heidenheim colour code	Technical data
1	DATA+	Grey	Data line 120Ω/RS-485
2	DATA-	Pink	
3	CLOCK+	Violet	Clock line 120Ω/RS-485 (200—400kHz)
4	CLOCK-	Yellow	
5	A+	Green/black	1Vpp (±0,5V); impedance 120Ω; Max.input 350 kHz
6	A-	Yellow/black	
7	B+	Blue/black	1Vpp (±0,5V); impedance 120Ω; Max.input 350 kHz
8	B-	Red/black	
9	GND	White/green	Input ground
10	Encoder voltage	Brown/green	Selectable encoder voltages: 5V, 12V and 15V Max.current consumption 300mA

Table 3-28. I/O terminals on OPT-BB, terminal X6

I/O terminals on OPT-BB, terminal X7

Terminal		Technical data
1	SimA+	Incremental pulse output A (differential), 0° (square wave, signal level RS-422); Impedance 120Ω; Input hysteresis ±5mV
2	SimA-	
3	SimB+	Incremental pulse output B (differential), 0° (square wave, signal level RS-422); Impedance 120Ω; Input hysteresis ±5mV
4	SimB-	
5	Not used	
6	Not used	
7	FDIN1	Fast digital input 1; HTL; Min.pulse length 50µs
8	CMA	Common FDIN1
9	FDIN2	Fast digital input 2; HTL; Min.pulse length 50µs
10	CMB	Common FDIN2

Table 3-29. I/O terminals on OPT-BB, terminal X7

OPT-BB

Jumper selections

On the OPT-BB board, there is one jumper block used to program the control voltage (auxiliary voltage). The factory default and other available jumper selections are presented below.

**Jumper block X11
Auxiliary voltage level**

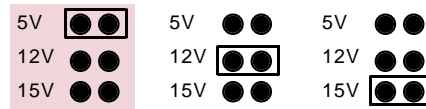

= Factory default

NOTE! It is recommended to use a +12 or +15 supply voltage instead of 5 V.

This is because our interface does not support "sense" function to compensate voltage drop which results in a cable length limit of about 60 m with 0.5 mm² wire section for the supply. The problem does not exist with 12 or 15 v supply.

If 5V is used, it is recommended to use two or more wires in parallel for supply connection.

OPT-BB board parameters

Code	Parameter	Min	Max	Default	Selections	Description
7.3.1.1	Reverse	0	1	0	0=No 1=Yes	Manually selectable rotation direction
7.3.1.2	Reading rate	0	4	1	0=Not used 1=1 ms 2=5 ms 3=10 ms 4=50 ms	Incremental pulse reading rate. Note: Use value 1 in Closed Loop mode.
7.3.1.3	Interpolation	0	1	0	0=No 1=Yes	If activated, the sinusoidal incremental pulses are used to calculate the polar angle in order to optimize the encoder accuracy

Table 3-30. OPT-BB board parameters

OPT-BB board monitoring values

Code	Monitored value	Unit	Description
7.3.2.1	Encoder frequency	Hz	Motor speed in Hz calculated from encoder pulses
7.3.2.2	Encoder speed	rpm	Motor speed in rpm calculated from encoder pulses
7.3.2.3	Encoder position	-	Absolute position of encoder read from Endat
7.3.2.4	Encoder revolution		
7.3.2.5	Encoder fault		
7.3.2.6	Encoder warning		
7.3.2.7	Encoder messages		Number of messages between encoder and NXOPTBB

Table 3-31. OPT-BB board monitoring values

OPT-BB board information pages

Code	Information	Unit	Description
7.3.3.1	Encoder type		0 = No encoder connected 1–4 = Incremental linear encoder 5 = Linear absolute encoder 6 = Unknown 7 = Linear absolute encoder 8 = Unknown 9–12 = Rotational incremental/angular encoder 13 = Absolute encoder (singleturn) 14 = Unknown 15 = Absolute encoder (multiturn) 16 = Unknown
7.3.3.2	Pulses/Revolution		Sinusoidal pulses/revolution
7.3.3.3	Position bits	bit	Accurate position 1–1024 (10bit = $2^{10} = 1024$)
7.3.3.4	Revolution bits	bit	Accurate number of revolutions 1–1024 (10bit = $2^{10} = 1024$)

Table 3-32. OPT-BB board information pages

OPT-BB option board status LEDs

Yellow LED

LED:	Meaning
OFF	Option board not activated
ON	Option board in initialisation state waiting for activation command from the frequency converter
Blinking fast (once/sec)	Option board is activated and in RUN state <ul style="list-style-type: none"> Option board is ready for external communication
Blinking slow (once/5 s)	Option board is activated and in FAULT state <ul style="list-style-type: none"> Internal fault of option board

Green LED

LED:	Meaning
OFF	Option board not activated
ON	Encoder is being initialised Option board is reading encoder parameters
Blinking fast (once/s)	Encoder detected by option board Option board receives data from encoder
Blinking slow (once/5 s)	Encoder detected by option board Option board cannot read encoder data or data is invalid (CRC error, broken cable etc.)

3.3 Adapter Boards OPT-D_

The adapter boards do not provide any additional I/O but are used to connect the frequency converter to a Vacon communication bus (System Bus, SPI, CAN). Note that if you use any of the major *fieldbuses* (Profibus, Modbus etc.) for communication you will need a corresponding *fieldbus board*. For more information, see the specific fieldbus board manual.

Note: Do not plug two adapter boards into the same control board in order to avoid incompatibility problems.

FC type	I/O board	Allowed slots	Description
NXP	OPT-D1	D,E	System Bus adapter board
NXP	OPT-D2	(B,)D,E	System Bus adapter board with interface to fast monitoring bus
NXS NXP	OPT-D3	D,E	RS-232 adapter board
NXP	OPT-D6	B,D,E	Monitor Bus adapter board for Vacon NXP

Table 3-33. Vacon NX adapter boards

3.3.1 OPT-D1

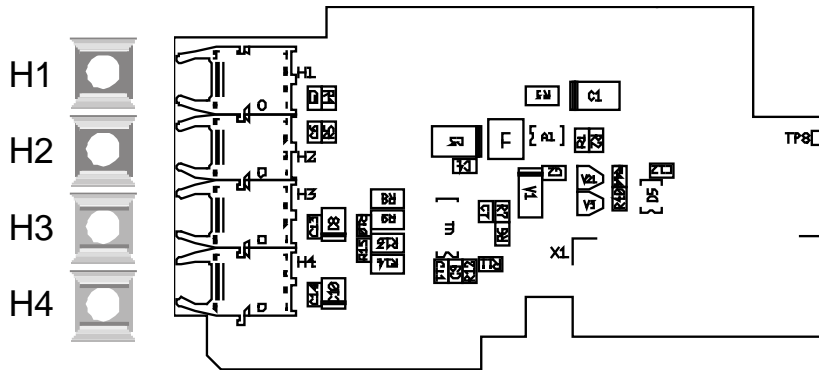

- Description:* System Bus adapter board for Vacon NXP
- Allowed slots:* D, E
- Type ID:* 17457
- Terminals:* Double optical input and output terminals.
Agilent HFBR-1528 (Receiver), HFBR-2528 (Transmitter).
- Jumpers:* None
- Board parameters:* None

I/O terminals on OPT-D1

Terminal		Technical information
1	H1	System Bus optical input 1 (RX1) Use 1-mm optical cable (e.g. Agilent HFBR-RUS500 & HFBR-4531/4532/ 4533 connectors)
2	H2	System Bus optical input 2 (RX2) Use 1-mm optical cable (e.g. Agilent HFBR-RUS500 & HFBR-4531/4532/4533 connectors)
3	H3	System Bus optical output 1 (TX1) Use 1-mm optical cable (e.g. Agilent HFBR-RUS500)
4	H4	System Bus optical output 2 (TX2) Use 1-mm optical cable (e.g. Agilent HFBR-RUS500)

Table 3-34. OPT-D1 I/O terminals

Note: The terminals of the board are protected with a rubber pin. Be sure to leave the pin in the unused terminals in order to avoid disturbances.

OPT-D1

Connections between frequency converters with OPT-D1

Basic connection:

Connect the output 1 of Device 1 to the input 2 of Device 2 and the input of Device 1 to the output 2 of Device 2. Note that in the end devices one terminal pair remains unused. See *Figure 3-13* below.

Max. number of devices in line	Max. speed achieved [Mbit/s]
3	12
6	6
12	3
24	1.5

Table 3-35.

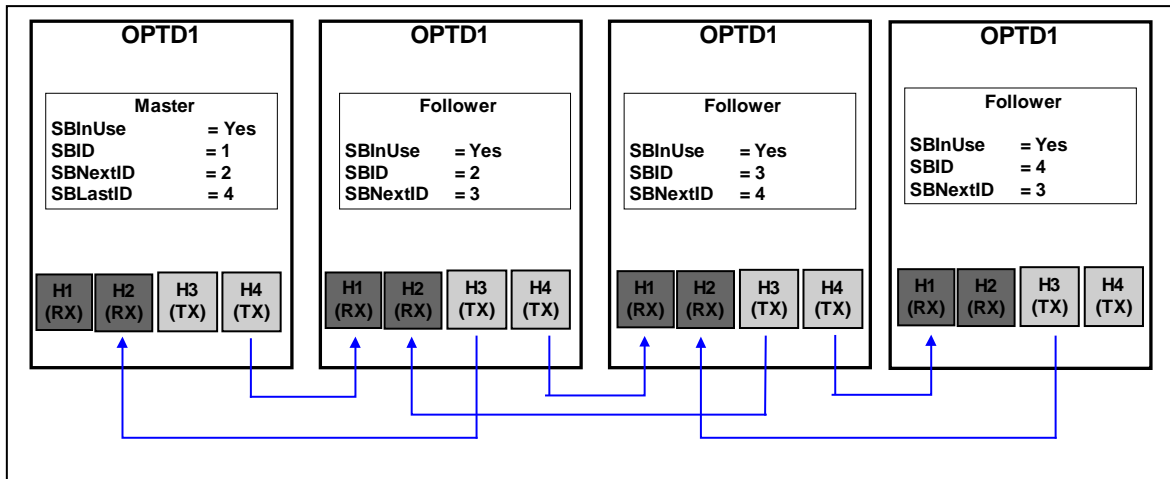
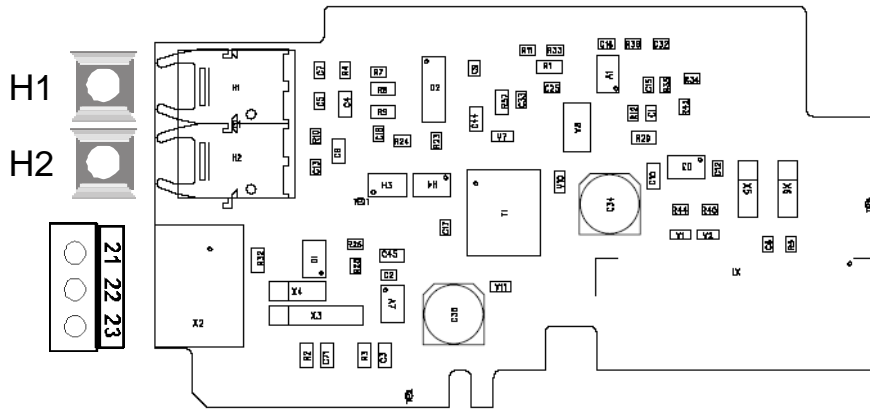

Figure 3-13. Basic connection of frequency converters with OPT-D1

3.3.2 OPT-D2



Note! This figure presents the layout of D2 board version H or later. See Chapter Jumper selections below.

Description: System Bus adapter board for Vacon NXP with single optical input and output; Interface to fast monitor bus used by the NCDrive PC tool.

Allowed slots: (B,)D, E; **Note:** If only the Monitor Bus (terminals 21 to 23) will be used, the board can also be placed in slot B. The System Bus is then unavailable. Remove therefore jumpers X5 and X6. See page 70.

Type ID: 17458

Terminals: Single optical input and output; one screw terminal block (M3), Agilent HFBR-1528 (Receiver), HFBR-2528 (Transmitter).

Jumpers: 4; X3, X4, X5 and X6. See page 70.

Board parameters: None

I/O terminals on OPT-D2

Terminal		Technical information
1	H1	System Bus optical input 1 (RX1) Use 1-mm optical cable (e.g. Agilent HFBR-RUS500 & HFBR-4531/4532/ 4533 connectors) Note: Not available if the board is placed in slot B
2	H2	System Bus optical output 1/2 (TX1/TX2); Selected with jumper X5 Use 1-mm optical cable (e.g. Agilent HFBR-RUS500 & HFBR-4531/4532/4533 connectors) Note: Not available if the board is placed in slot B
21	CAN_L	Monitor Bus negative data
22	CAN_H	Monitor Bus positive data
23	CAN_SHIELD	Monitor Bus shield

Table 3-36. OPT-D2 I/O terminals

OPT-D2

Jumper selections

There are four jumper blocks on the OPT-D2 board. The factory defaults and other available jumper selections are presented below.

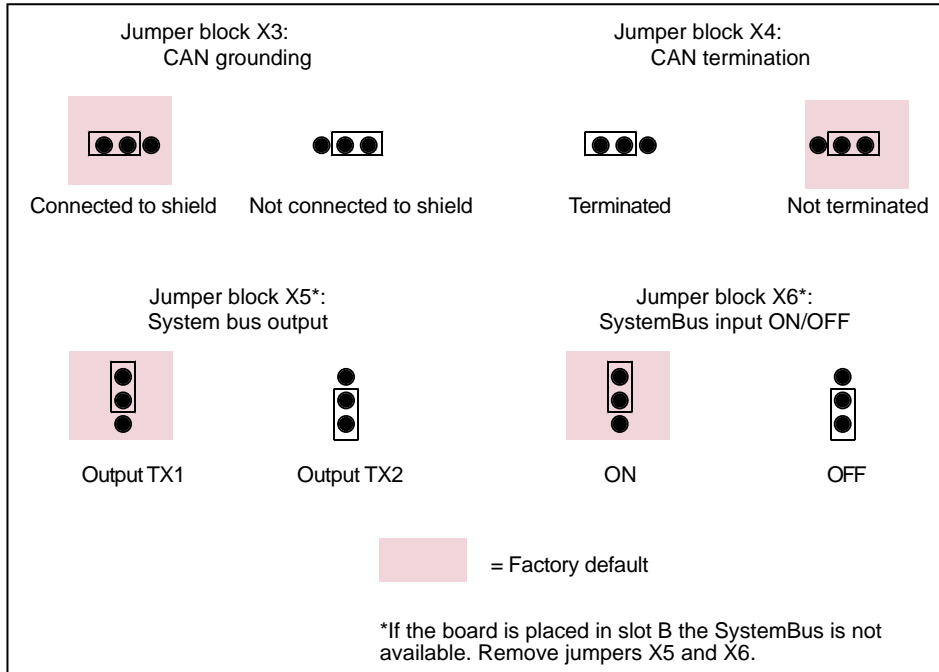

Figure 3-14. Jumper selections for OPT-D2, up to version G.

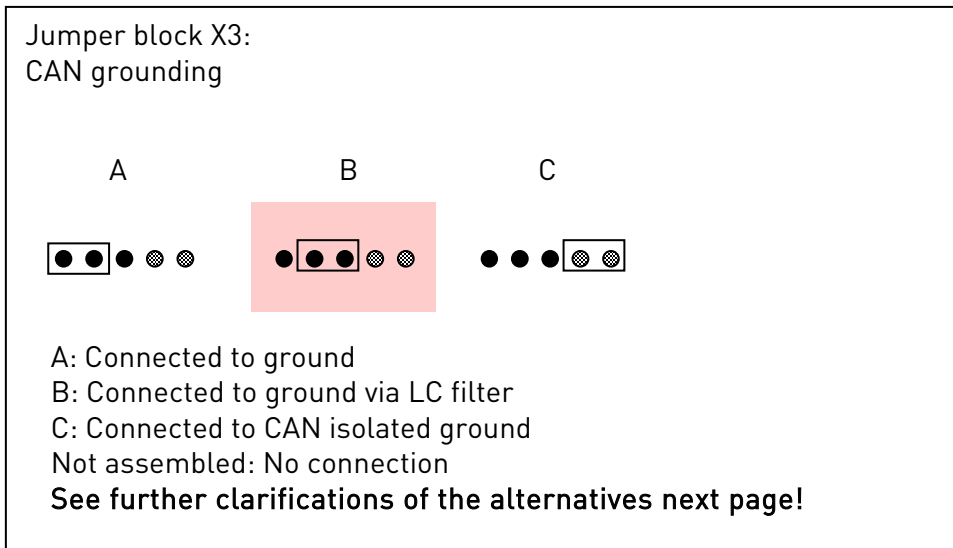

Figure 3-15. X3 jumper selections for OPT-D2, version H and later.

Note! Position C can be used with 3- or 4-wire can cable to interconnect isolated CAN ground levels in the network. It is recommended to connect the cable shield to the grounding clamp of the drive

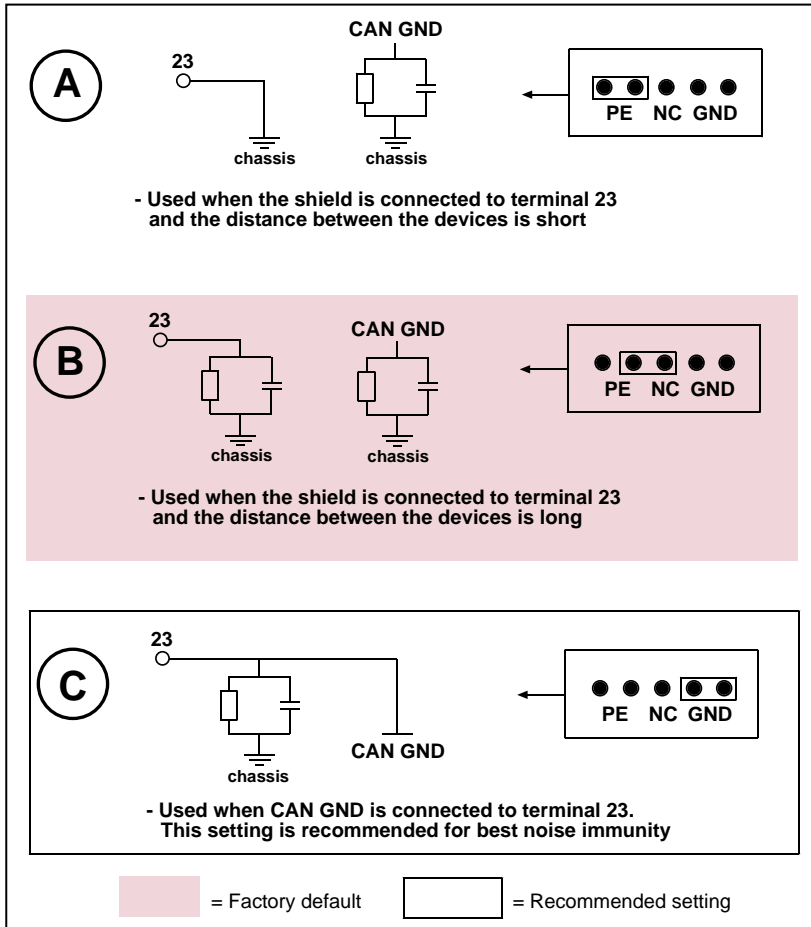

Figure 3-16. CAN grounding alternatives

Alternative connection of "CAN GND" signal: connect 'CAN GND' together between all nodes. Use the signal wire inside the shield for this purpose, see figure below:

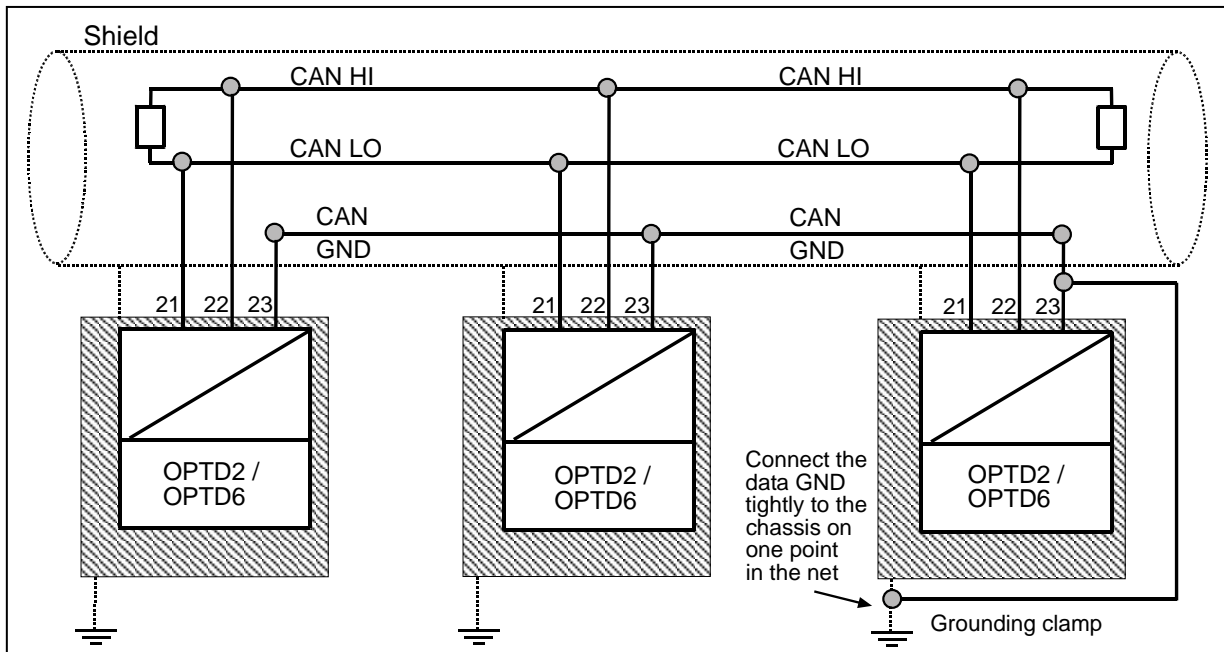

Figure 3-17. Alternative connection of "CAN GND" signal

Connections between frequency converters with OPT-D2

Special connection:

In this connection example, the leftmost device is the Master and the others are slaves. The Master can send and receive data from the slaves. The slaves cannot communicate with each other. Changing of masters is not possible, the first device is always the Master.

The OPT-D2 board in the Master has the default jumper selections, i.e. X6:1-2, X5:1-2. The jumper positions have to be changed for the slaves: X6: 1-2, **X5:2-3**.

Max. number of devices in line	Max. speed achieved [Mbit/s]
3	12
6	6
12	3
24	1.5

Table 3-37.

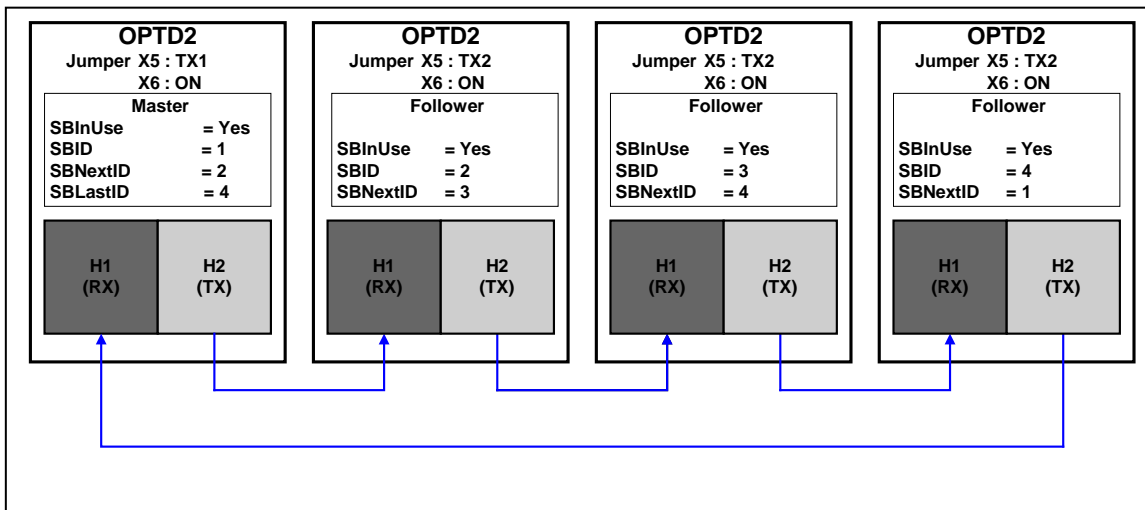
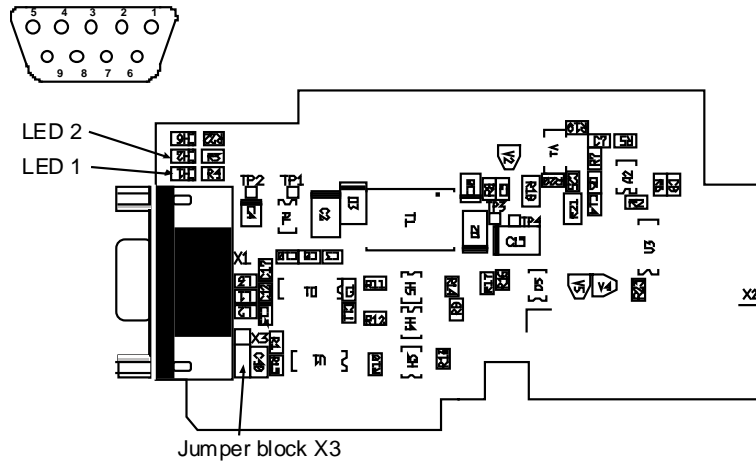

Figure 3-18. Connection example of frequency converters with OPT-D2

3.3.3 OPT-D3



Description: RS-232 adapter board. Galvanically decoupled. Used mainly for application engineering to connect another keypad.

Allowed slots: D, E.

Type ID: 17459

Terminals: 9-pin female sub-D-connector

Jumpers: 1; X3 (see page 74)

Board parameters: None

I/O terminals on OPT-D3

Terminal		Technical information
1		
2	TxD	Transmit data
3	RxD	Receive data
4		
5	GND	Ground isolated
6	+9V	+9V isolated
7		
8		
9		

Table 3-38. OPT-D3 I/O terminals

Note:

If OPT-CI Ethernet Option board is used for NC Tools connection, like NCLoad, the OPT-D3 board can not be used.

Jumper selections

There is one jumper block on the OPT-D3 board. The factory defaults and other available jumper selections are presented below:

**Jumper block X3:
Connector connection to GND**



Connected to GND
through RC filter



Connected
directly to GND

OPT-D3 option board status LEDs

LED:	Meaning
Green (LED 1)	Receiving data
Red (LED 2)	Transmitting data

3.3.4 OPT-D6

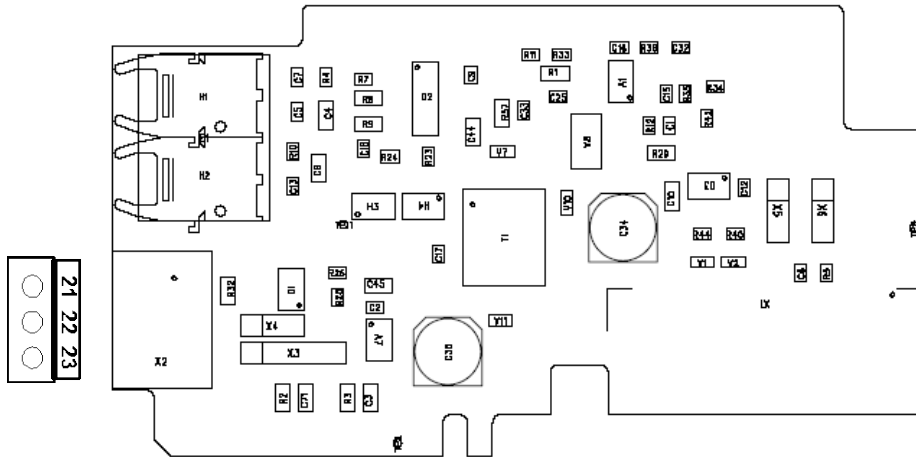

Note! This figure presents the layout of D6 board version F or later. See Chapter Jumper selections below.

Description: Monitor Bus adapter board for Vacon NXP. Interface to fast monitor bus used by the NCDrive PC tool.

Allowed slots: B, D, E.

Type ID: 17462

Terminals: One screw terminal block (M3)

Jumpers: 2; X3, X4.

Board parameters: None

I/O terminals on OPT-D6

Terminal	Technical information	
21	CAN_L	Monitor Bus negative data
22	CAN_H	Monitor Bus positive data
23	CAN_GND	Monitor Bus ground

Table 3-39. OPT-D6 I/O terminals

Jumper selections

There are two jumper blocks on the OPT-D6 board. The factory defaults and other available jumper selections are presented below:

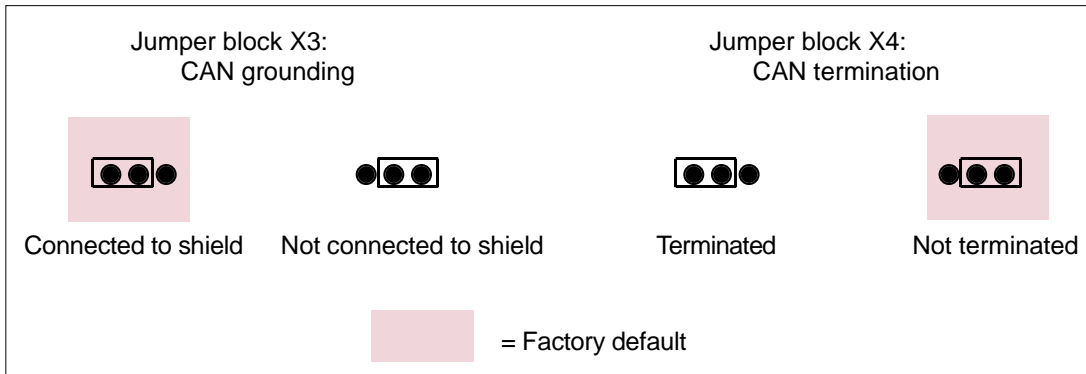

Figure 3-19. Jumper selections for OPT-D6

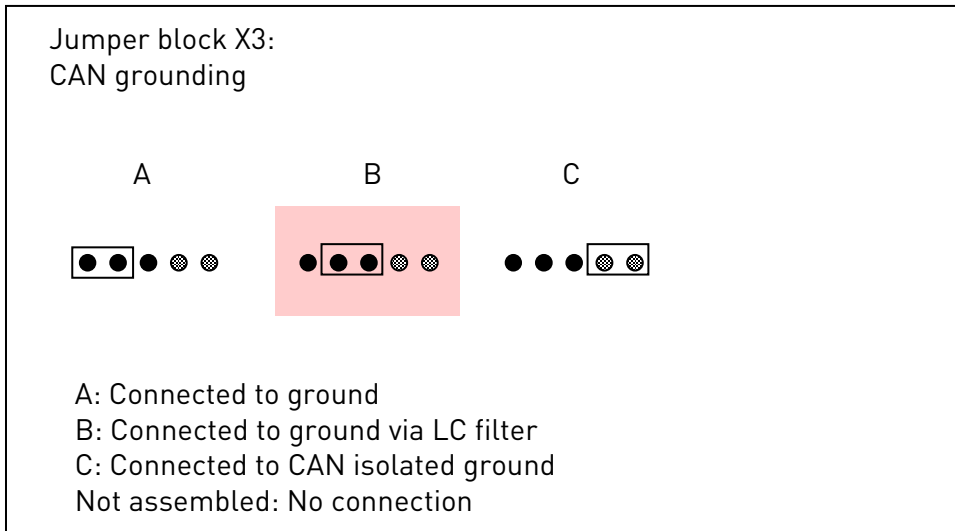

Figure 3-20. X3 jumper selections for OPT-D6, version F and later.

Note! Position C can be used with 3- or 4-wire can cable to interconnect isolated CAN ground levels in the network. It is recommended to connect the cable shield to the grounding clamp of the drive. See more details of the alternatives on page 71.

4. VACON OPTION BOARDS – OPERATIONAL DETAILS

Board type	Slots allowed ⁶⁾	ID	DI	DO	AI (mA/V)	AI (mA), isol.	AO (mA/V)	AO (mA), isol.	RO (no/nc)	RO (no)	+10V ref	TI	+24V/EXT +24V	42-240 VAC	DI (Enc. 10-24V)	DI (Enc. RS-422)	Out +5/+15V/+24V	Out +15/+24V	Pt-100
Basic boards																			
OPT-A_																			
OPT-A1	A	16689	6	1	2		1				1		2						
OPT-A2	B	16690							2										
OPT-A3	B	16691							1	1		1							
OPT-A4 ⁴⁾	C	16692														3	1		
OPT-A5 ⁴⁾	C	16693													3			1	
OPT-A7	C	16695		2											6			1	
OPT-A8	A	16696	6	1	2 ¹⁾		1 ¹⁾				1 ¹⁾		2						
OPT-A9 ³⁾	A	16697	6	1	2		1				1		2						
OPT-AE ⁴⁾	A	16709		2											3				
OPT-AL	A	16716		1	2 ⁸⁾		2 ⁹⁾							6					
OPT-AN	A	16718	6		2 ¹⁰⁾		2 ¹⁰⁾				1 ¹¹⁾		1						
I/O expander boards																			
OPT-B_																			
OPT-B1	BCDE	16945	6 ⁵⁾	6 ⁵⁾															
OPT-B2	BCDE	16946							1	1		1							
OPT-B4	BCDE	16948				1 ²⁾		2 ²⁾					1						
OPT-B5	BCDE	16949								3									
OPT-B8	BCDE	16952																	3
OPT-B9	BCDE	16953								1				5					
OPT-BB	C	16962 16963													2				

Table 4-1. Vacon option boards, types A and B

Adapter boards NXOPT-D			
OPT-D1	DE	17457	System Bus adapter board: 2 x fiber optic pairs
OPT-D2 ⁷⁾	(B)DE	17458	System Bus adapter board: 1 x fiber optic pair & CAN bus adapter (galvanically decoupled)
OPT-D3	DE	17459	RS232 adapter card (galvanically decoupled)
OPT-D6	BDE	17462	MonitorBus adapter board (galvanically decoupled)

Table 4-2. Vacon option boards, type D

Explanations:

- 1) Analogue inputs AI1 and AI2, analogue output AO1 and voltage reference +10Vref galvanically decoupled (all these in same potential)
- 2) Analogue input AI1 and analogue outputs AO1 and AO2 galvanically decoupled from each other and other electronics
- 3) Similar to OPT-A1 only with bigger terminals for 2.5mm² wires
- 4) Special application required for use in NXS
- 5) Bidirectional terminals
- 6) In case of several optional slots, the bold slot letter indicates the factory default slot (NOTE: not applicable if several boards with the same default slot are installed)
- 7) If the board is placed in slot B the SystemBus is not available; only the Monitor Bus can be used. Remove jumpers X5 and X6.
- 8) AI1 0-10V, AI2 -10V...+10V
- 9) AO1 mA, AO2 V
- 10) 2 (mA/V), incl. -10...+10V
- 11) Also -10V ref

Board type	NXS, NXP							NXL
	Basic NXFIF01	Standard NXFIF02	Local- Remote NXFIF03	Multi-step speed NXFIF04	PID NXFIF05	Multi- purpose NXFIF06	PFC NXFIF07	Multi- control
Basic boards								
OPT-A_								
OPT-A1	●	●	●	●	●	● ⁶⁾	● ⁶⁾	
OPT-A2	●	●	●	●	●	● ⁶⁾	● ⁶⁾	
OPT-A3		●	●	●	●	● ⁶⁾	● ⁶⁾	
OPT-A4	■	■	■	■	■	■	■	
OPT-A5 (NXP only)	■	■	■	■	■	■	■	
OPT-A7 (NXP only)	▲	▲	▲	▲	▲	▲	▲	
OPT-A8	●	●	●	●	●	● ⁶⁾	● ⁶⁾	
OPT-A9	●	●	●	●	●	● ⁶⁾	● ⁶⁾	
OPT-AE (NXP only)	■	■	■	■	■	■	■	
OPT-AL	●	●	●	●	●	●	●	
I/O expander boards								
OPT-B_								
OPT-B1						● ⁶⁾	● ⁶⁾	
OPT-B2						● ⁶⁾	● ⁶⁾	*
OPT-B4		●	●	●	●	● ⁶⁾	● ⁶⁾	*
OPT-B5						● ⁶⁾	● ⁶⁾	*
OPT-B8					●	●	●	
OPT-B9						● ⁶⁾	● ⁶⁾	
Adapter boards								
OPT-D_								
OPT-D1 (NXP only)	■	■	■	■	■	■	■	
OPT-D2 ⁷⁾ (NXP only)	■	■	■	■	■	■	■	
OPT-D3	●	●	●	●	●	●	●	
OPT-D6 ⁷⁾ (NXP only)	■	■	■	■	■	■	■	

Table 4-3. All in One applications and supported Vacon NX option boards

- = Used with this application (NXS, NXP)
- = Used with this application (NXP)
- ▲ = Used with special applications only

- 6) = Digital inputs, digital outputs, analogue inputs and analogue outputs can be programmed
- 7) = This board is supported by specified applications if program NC_{sys}Drive is used
- *) = Used with this application (NXL)

VACON

DRIVEN BY DRIVES

Find your nearest Vacon office
on the Internet at:

www.vacon.com

